

GENERALITÀ

- Dati di identificazione e ubicazione su vettura	1
- Dimensioni	2
- Pesi	3
- Prestazioni - Consumo carburante	4
- Rifornimenti	5
- Caratteristiche dei lubrificanti	6

DATI TECNICI

MOTORE

- Dati caratteristici	7
- Basamento e organi del manovellismo	8
- Testa cilindri e organi della distribuzione	12
- Lubrificazione	15
- Raffreddamento - Alimentazione	16

FRIZIONE	18
-----------------	----

CAMBIO E DIFFERENZIALE	19
-------------------------------	----

FRENI	25
--------------	----

STERZO	26
---------------	----







RUOTE	27
--------------	----

SOSPENSIONE ANTERIORE	28
------------------------------	----

SOSPENSIONE POSTERIORE	29
-------------------------------	----

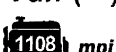
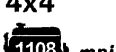
IMPIANTO ELETTRICO	31
---------------------------	----

- Avviamento	32
- Ricarica	34
- Iniezione-accensione elettronica	36

	AUTOTELAIO	MOTORE	VERSIONE	3 porte	CAMBIO
					5 marce
Panda 	ZFA 141 000	187 A 1000	141 AW53A 04	●	●
Panda CITIVAN 	ZFA 141 000	187 A 1000	141 AW53C AX	●	●
Panda Van (*) 	ZFA 141 000	187 A 1000	141 AW53D AX	●	●
Panda Van (**) 	ZFA 141 000	187 A 1000	141 AW53D BX	●	●
Panda 4x4 	ZFA 141 000	187 A 1000	141 AW53B 05	●	●
Panda 4x4 CITIVAN 	ZFA 141 000	187 A 1000	141 AW53E AX	●	●
Panda 4x4 Van (*) 	ZFA 141 000	187 A 1000	141 AW53F AX	●	●
Panda 4x4 Van (**) 	ZFA 141 000	187 A 1000	141 AW53F BX	●	●

(*) Portata 260 kg

(**) Portata 280 kg

UBICAZIONE SU VETTURA DEI DATI DI IDENTIFICAZIONE

Tipo e numero del motore

È stampigliato sul basamento lato distribuzione, in prossimità della testa cilindri.

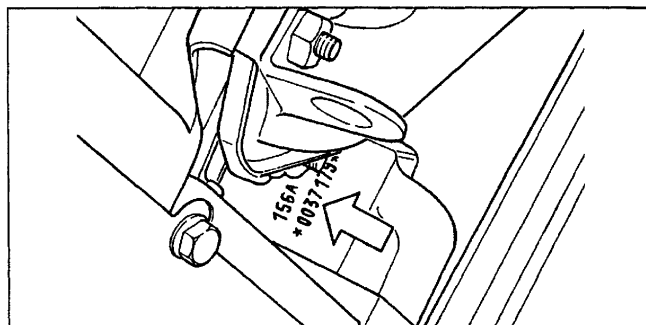

3X001DA01

A Codice di identificazione del tipo di veicolo e numero del telaio

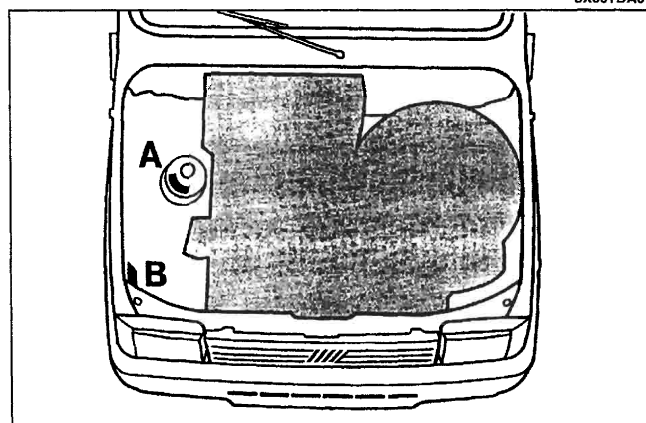

3X001DA02

00.0

B. Targhetta riassuntiva di marcatura (normativa C.E.E.)

FIAT	A		
	B		
	C	D	
	E	Kg	
	F	Kg	
	1-	G	Kg
	2-	H	Kg
	MOTORE - ENGINE	I	
N	VERSIONE - VERSION	L	
	N° PER RICAMBI N° FOR SPARES	M	

- A. Nome del costruttore
- B. Numero di omologazione
- C. Codice di identificazione del tipo di veicolo
- D. Numero progressivo di fabbricazione dell'autotelaio
- E. Peso massimo autorizzato del veicolo a pieno carico
- F. Peso massimo autorizzato a pieno carico del veicolo più rimorchio
- G. Peso massimo autorizzato sul primo asse (anteriore)
- H. Peso massimo autorizzato sul secondo asse (posteriore)
- I. Tipo del motore
- L. Codice versione carrozzeria
- M. Numero per ricambi
- N. Valore corretto del coefficiente di assorbimento fumosità (solo per motori Diesel)

3X002DA01

DIMENSIONI (in mm)

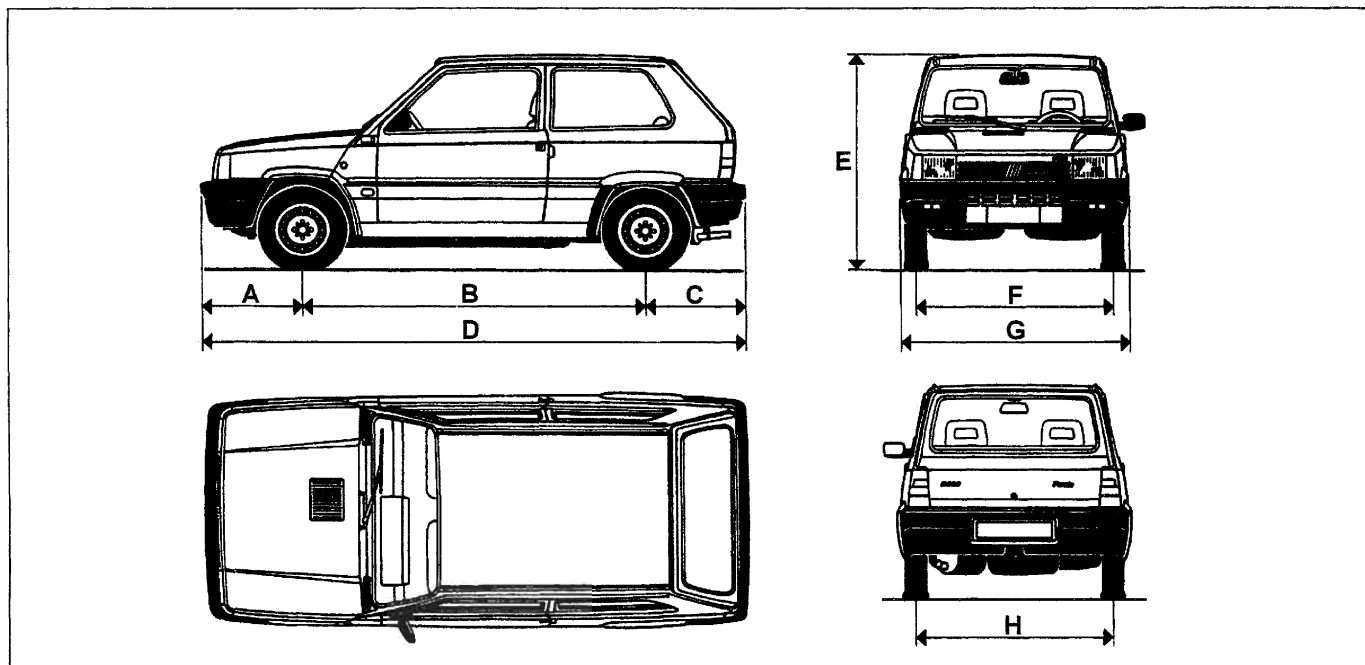

3X002DA02

Modello	A	B	C	D	E	F	G	H
Panda	629	2159	620	3408	1435	1263	1494 (*)	1265
Panda 4x4	628	2170	610	3408	1468	1260	1500	1264

L'altezza si intende a vettura scarica.



















Capacità del vano di carico (norme VDA):

- con sedile posteriore in posizione normale 204 dm³
- con sedile posteriore ribaltato (carico fino a filo padiglione) 822 dm³

Capacità del vano di carico per versioni Van: 1000 dm³

(*) 1500 mm per versioni con fasce paracolpi

PESI
(valori espressi in kg)

MOTORIZZAZIONE		 1108 mpi Panda	 1108 mpi Panda Van	 1108 mpi CITIVAN	 1108 mpi Panda 4x4	 1108 mpi Panda Van 4x4	 1108 mpi CITIVAN 4x4
		715	755(*) 775(**)	735	800	840(*) 860(**)	820
+370=	 	1150	-	-	1220	-	-
+ 330(*) 350(**)	 190 (*)  210 (**)  260 (*)  280 (**)	-	1150	-	-	1220	-
+370=	 	-	-	1150	-	-	1220
Carichi massimi ammessi sugli assi ■	asse anteriore 	580	580	580	590	590	590
	asse posteriore 	630	630	630	680	680	680
Carico massimo ammesso sul tetto		50	50	50	50	50	50
Carico sulla sfera del gancio di traino		56	56	56	63	63	63
 	Senza sistema frenante	350	350	350	400	400	400
	Con sistema frenante	800	800	800	900	900	900





(*) Versioni con portata 260 kg











(**) Versioni con portata 280 kg

■ Carichi che non devono essere mai superati. È responsabilità dell'utente disporre le merci nel vano bagagli e/o sul piano di carico in modo da rispettare tali massimi.

NOTA PER VERSIONI ACCESSORIE: In presenza di equipaggiamenti speciali (condizionatore d'aria non di serie, tetto apribile, dispositivo traino rimorchio), il peso a vuoto aumenta e pertanto può diminuire la portata utile, nel rispetto dei carichi massimi ammessi.

00.0

























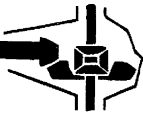
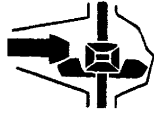

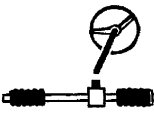
MOTORIZZAZIONE	 1108 mpi Panda	 1108 mpi Panda Van	 1108 mpi Panda 4x4	 1108 mpi Panda 4x4 Van
----------------	---	---	---	---

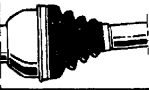
 Velocità km/h		36		27	
		69		50	
		106		81	
		130		106	
		140		130	
		38		28	
Massima pendenza superabile  %		34		38	
Consumo carburante secondo Dir. 199/100/CE (litri/100 km) 	Ciclo urbano	8,3	–	8,7	–
	Ciclo extraurbano	5,3	–	6,5	–
	Consumo combinato	6,4	–	7,3	–
Consumo carburante secondo norme CUNA (litri x 100 km) 		–	5,7	–	7,6

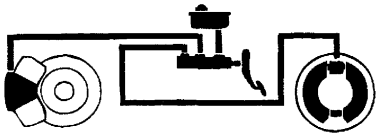
I consumi di carburante secondo la direttiva 1999/100/CE, espressi in litri x 100 km e riportati in tabella, sono determinati sulla base di prove omologative prescritte da specifiche Direttive Europee. Per la determinazione del consumo vengono seguite le seguenti procedure:

- **ciclo urbano:** inizia con un avviamento a freddo quindi viene effettuata una guida che simula l'utilizzo di circolazione urbana della vettura;
- **ciclo extraurbano:** viene effettuata una guida che simula l'utilizzo di circolazione extraurbana della vettura con frequenti accelerazioni in tutte le marce; la velocità di percorrenza varia da 0 a 120 km/h;
- **consumo combinato:** viene determinato con una ponderazione di circa il 37% del ciclo urbano e di circa il 63% del ciclo extraurbano.

Avvertenza Tipologia di percorso, situazioni di traffico, condizioni atmosferiche, stile di guida, stato generale della vettura, livello di allestimento/dotazioni/accessori, carico della vettura, presenza di portapacchi sul tetto, altre situazioni che penalizzano la penetrazione aerodinamica o la resistenza all'avanzamento possono portare a valori di consumo diversi da quelli rilevati.

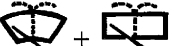
Rifornimento	Parti da rifornire	Quantità			
		dm ³ (l)	(kg)		
 Benzina con N.O. minimo ammesso 95 tassativamente senza Pb		Panda	43	-	
		Panda 4x4	30	-	
 50% + (*) 	  	Capacità totale impianto di raffreddamento		5,20	-
 SELENIA 20K (*) SELENIA PERFORMER	Capacità totale 			3,88	3,45
(*) Consigliato per temperature inferiori a -20°C	Capacità parziale (sostituzione periodica) 			3,75	3,33
 a= TUTELA CAR ZC 75 SYNTH 		a	2,40	2,15	
b= TUTELA GI/A 		b	-	-	
 TUTELA W140/MDA	a 	b  Autobloccante	a	-	1,20
			b	-	-
 a= TUTELA GI/A	a 	b 	a	-	-
 b= K 854			b	-	0,10
 c= TUTELA MRM2	c 		c	-	0,095
 TUTELA DOT 4		Capacità totale		0,39	0,39
 + 	 3%  - 20°C 50% < - 20°C 100%			3,50	-

(*) Acqua distillata

00.0

Denominazione prodotto	Descrizione Designazione internazionale	Applicazione
SELENIA 20K	Olio motore multigrado semisintetico di gradazione SAE 10W40. Supera le specifiche ACEA A3-96/CCMC G5 e API SJ	Temperatura -25°C ÷ 40°C
SELENIA PERFORMER	Olio motore multigrado, minerale o semisintetico di gradazione SAE 5W30. Supera le specifiche ACEA A1 e API SJ	Temperatura inferiore a -20°C
TUTELA CAR ZC 75 SYNTH	Olio sintetico SAE 75W-80EP. Supera le specifiche API GL 5 e MIL-L-2105 D LEV	Cambio meccanico e differenziale
TUTELA W140/MDA	Olio SAE 85 W-140 EP speciale per differenziali normali ed autobloccanti. Supera le specifiche API GL5 e MIL-L-2105 D	Differenziali ipoidi Differenziali auto – bloccanti
TUTELA GI/A	Olio tipo ATF DEXRON II D LEV, SAE 10W	Servosterzo idraulici Cambi di velocità automatici
TUTELA MRM2	Grasso al bisolfuro di molibdeno a base di saponi di litio idrorepellente, consistenza NLGI = 2	Giunti omocinetici
TUTELA MR3	Grasso a base di saponi di litio, consistenza NLGI = 3	Cuscinetti mozzi ruote tiranti sterzo, organi vari
TUTELA TOP 4	Fluido sintetico, NHTSA n° 116 DOT 4 ISO 4925, CUNA NC 956-01	Freni idraulici e comandi idraulici frizione
K 854	Grasso a base di saponi di litio, consistenza NLGI = 000, contenente bisolfuro di molibdeno	Scatole sterzo a cremagliera
SP 349	Grasso speciale compatibile con liquido freni	Correttore di frenata Boccola correttore di frenata comando tirantino a barra
Arexons DP1	Miscela di alcoli, acqua e tensioattivi CUNA NC 956-11	Da impiegarsi puro o diluito negli impianti tergilavacrystalli
Paraflu¹¹	Protettivo con azione anticongelante per impianti di raffreddamento a base di glicole monoetilenico inibito, CUNA NC 956-16	Circuiti di raffreddamento Percentuale di impiego 50% fino a -35°C









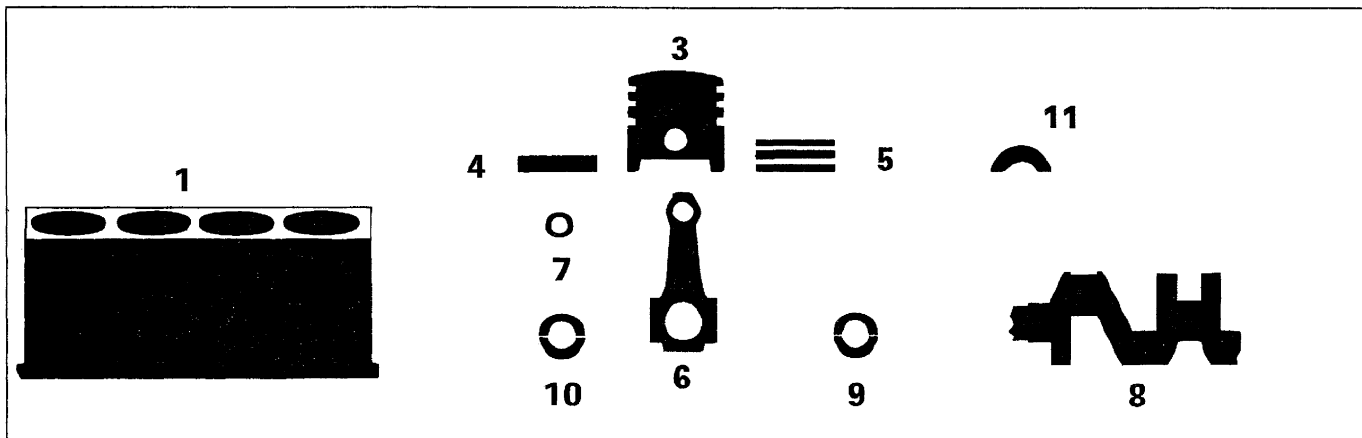

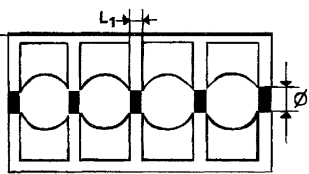

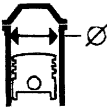

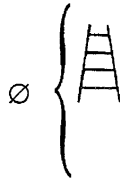

DATI CARATTERISTICI

	Ciclo	Otto a 4 tempi	
	Distribuzione	1 albero a camme in testa	
	Tipo alimentazione	Iniezione-accensione elettronica I.A.W. (M.P.I.)	
	Numero cilindri	4 in linea	
	Canna cilindro (alesaggio)	mm	70
	Corsa	mm	72
	Cilindrata	cm ³	1108
	Rapporto di compressione	9,6±2	
Volume camera di combustione	totale	cm ³	32,2
	nella testa cilindri	cm ³	23,41
	Potenza massima	kW (CV)	40 (54)
		1/min	5000
	Coppia massima	daNm (kgm)	8,8 (9,0)
		1/min	2750

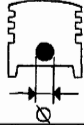
00.10



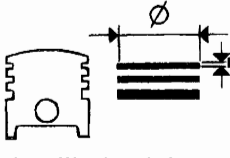

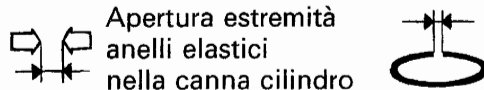
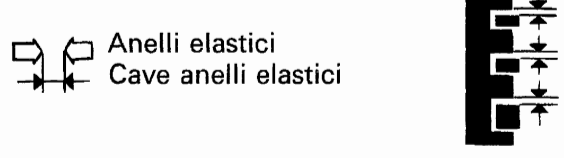



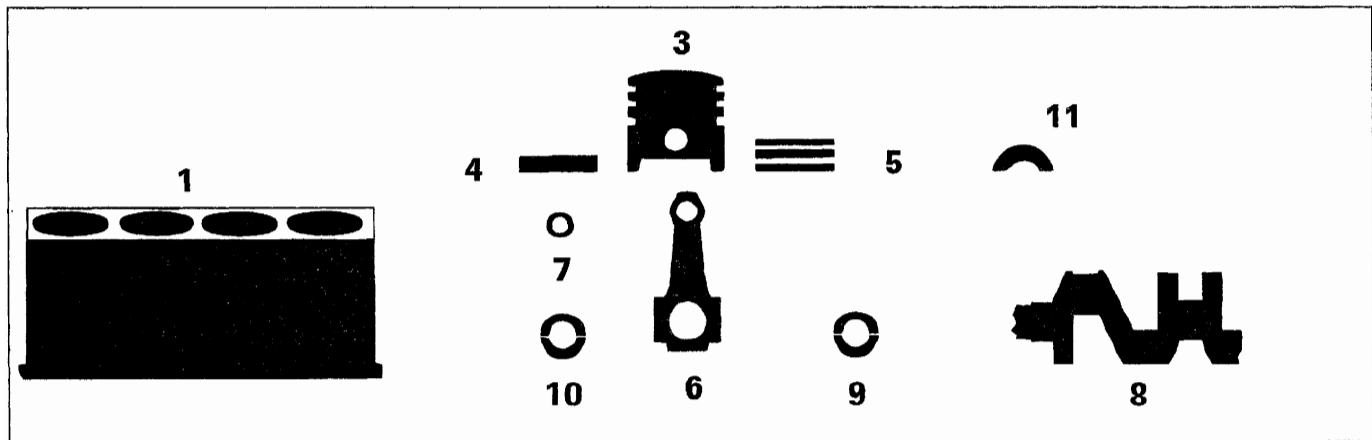



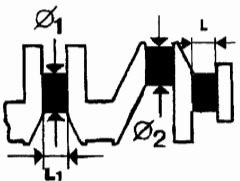

			
MISURE E ACCOPPIAMENTI		Valori in mm	
1  Supporti di banco	L_1		19,140 ÷ 19,200
	\varnothing 	1	47,705 ÷ 47,709
		2	47,709 ÷ 47,713
		3	47,713 ÷ 47,717
1  Canna cilindro	1		70,000 ÷ 70,010
	\varnothing 2		70,010 ÷ 70,020
	3		70,020 ÷ 70,030
3  Stantuffo	Y		8
	\varnothing 	A	69,960 ÷ 69,970
		B	69,970 ÷ 69,980
		C	69,980 ÷ 69,990
\varnothing  $>$			0,4
3  Differenza di peso fra stantuffi			± 5 g
3-1  Stantuffo - Canna cilindro			0,030 ÷ 0,050

MISURE E ACCOPPIAMENTI			
		Valori in mm	
3	 <p>Sede perno stantuffo</p>	∅	17,982÷17,986
3	 <p>Cave anelli elastici</p>	1	1,230÷1,250
		2	1,210÷1,230
		3	2,510÷2,530
4	 <p>Perno stantuffo</p>	∅	17,970÷17,974
4-3	 <p>Perno stantuffo - Sede perno</p>		0,008÷0,016
5	 <p>Anelli elastici</p>	1	1,175÷1,190
		2	1,175÷1,190
		3	2,475÷2,490
			0,4
5-1	 <p>Apertura estremità anelli elastici nella canna cilindro</p>	1	0,25÷0,45
		2	0,25÷0,45
		3	0,20÷0,45
5-3	 <p>Anelli elastici Cave anelli elastici</p>	1	0,040÷0,075
		2	0,020÷0,055
		3	0,020÷0,055

00.10

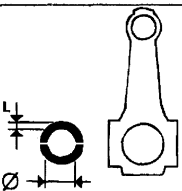

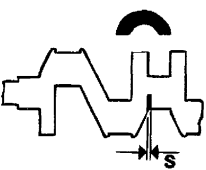





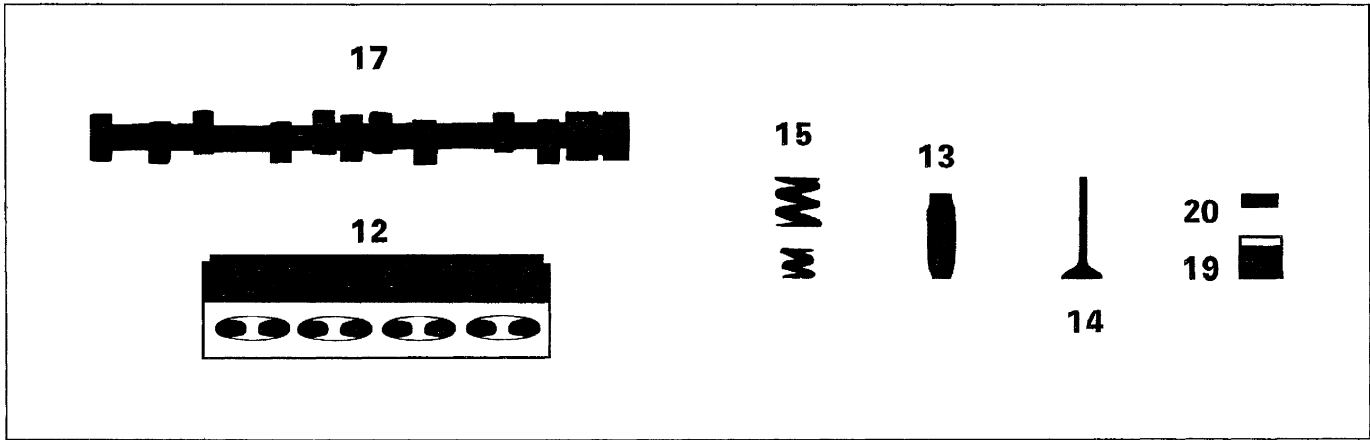

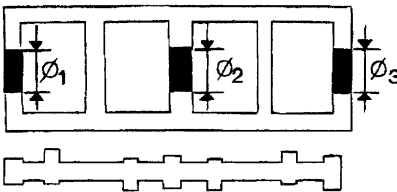
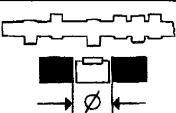
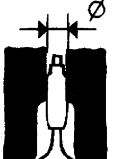
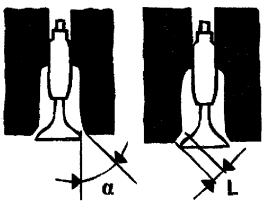
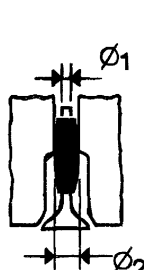



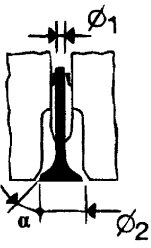

			
MISURE E ACCOPPIAMENTI		Valori in mm	
6		Sede boccola o perno piede di biella	\varnothing_1
		Sede cuscinetti di biella	\varnothing_2
4-6		Perno stantuffo Piede di biella	$0,014 \div 0,035$
8		Perni di banco	\varnothing_1
		1	$43,994 \div 44,000$
		2	$43,988 \div 43,994$
	3	$43,982 \div 43,988$	
Perni di biella	\varnothing_2	$37,990 \div 38,008$	
L	$23,975 \div 24,025$		
9		Cuscinetti di banco	L
		1	$1,836 \div 1,840$
		2	$1,841 \div 1,845$
3	$1,846 \div 1,850$		
\varnothing		$<$	$0,254 - 0,508$

			
MISURE E ACCOPPIAMENTI		Valori in mm	
	1		0,025 ÷ 0,043
9-8  Cuscinetti di banco - Perni	2		0,027 ÷ 0,045
	3		0,029 ÷ 0,047
	L		1,544 ÷ 1,548
10  Cuscinetti di biella	L		1,544 ÷ 1,548
			0,254-0,508
10-8  Cuscinetti di biella - Perni			0,024 ÷ 0,060
11  Semianelli di spallamento	S		2,310 ÷ 2,360
			0,127
11-8  Spallamento albero motore			0,055 ÷ 0,265

00.10

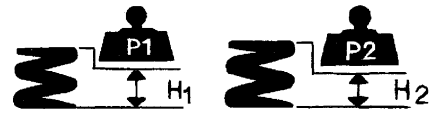
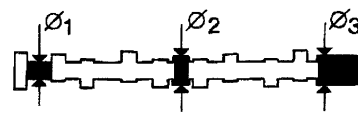
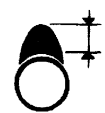

			
MISURE E ACCOPPIAMENTI		Valori in mm	
 <p>Supporti albero distribuzione</p>	\varnothing_1	24,045 ÷ 24,070	
	\varnothing_2	23,545 ÷ 23,570	
	\varnothing_3	24,045 ÷ 24,070	
 <p>12 Sede punterie su testa cilindri</p>	\varnothing	35,000 ÷ 35,025	
 <p>12 Sede guidavalvola Su testa cilindri</p>	\varnothing	12,950 ÷ 12,977	
 <p>Sede valvole</p>	α	45° ± 5'	
	L	circa 2	
 <p>13 Guidavalvola</p>	\varnothing_1	7,022 ÷ 7,040	
	\varnothing_2	13,010 ÷ 13,030	
	\varnothing_2 	0,05-0,10-0,25	

MISURE E ACCOPPIAMENTI			
			Valori in mm
13-12	 Guidavalvola Sede su testa cilindri	 	0,033÷0,080
14	 Valvola		\varnothing_1 6,982÷7,000
			\varnothing_2 31,20÷31,50
			α 45° 30'±5'
			\varnothing_1 6,982÷7,000
			\varnothing_2 27,20÷27,50
			α 45° 30'±5'
14-13	 Valvola - Guidavalvola		0,022÷0,058
15	 Molla valvola	P_1	18,74÷28,10 daN
		H_1	32,1
		P_2	58,4÷62,6 daN
		H_2	22,6
17	 Perno albero distribuzione	\varnothing_1	24,000÷24,015
		\varnothing_2	23,500÷23,515
		\varnothing_3	24,000÷24,015
17	 Alzata camma		8
			
17-12	 Perni albero distribuzione Sede su testa cilindri	\varnothing_1	0,030÷0,070
		\varnothing_2	0,030÷0,070
		\varnothing_3	0,030÷0,070
19	 Punteria	\varnothing	34,975÷34,995

Dati tecnici

Motore: testa cilindri e organi della distribuzione

Panda
gamma 2000

00.10

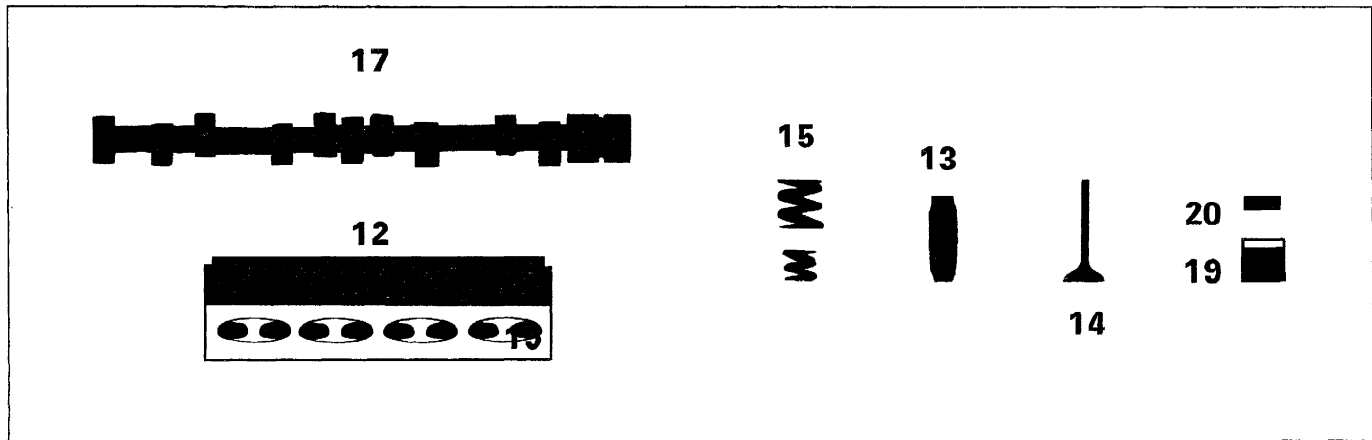





MISURE E ACCOPPIAMENTI

Valori in mm

19-12		Punteria Sede su testa cilindri		0,005-0,050
20		Piattello		3,200-4,700
17-20		per controllo messa in fase		0,8
		di funzionamento		0,40±0,05
				0,50±0,05

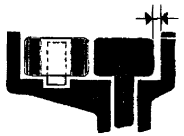
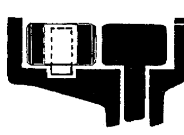
ANGOLI DI FASATURA

A	Aspirazione		inizio prima del P.M.S.	7°
B			fine dopo il P.M.I.	35°
C	Scarico		inizio prima del P.M.I.	37°
D			fine dopo il P.M.S.	5°

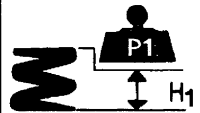



		
LUBRIFICAZIONE - Misure e accoppiamenti		Valori in mm
Circuito lubrificazione motore		a circolazione forzata, mediante pompa ad ingranaggi con filtro olio a cartuccia in serie
Pompa olio		ad ingranaggi a lobi
Comando pompa		mediante albero motore
Valvola regolazione pressione olio		incorporata nel coperchio anteriore albero motore
 Fra sede corpo pompa ed ingranaggio condotto		0,080÷0,186
 tra il lato superiore degli ingranaggi e il coperchio pompa		0,025÷0,056
Filtro a portata totale		a cartuccia
Trasmittitore insufficiente pressione olio		elettrico
   Pressione di funzionamento alla temperatura di 100°C		3,43÷4,9 bar
 Molla valvola regolazione pressione olio	P ₁	4,45÷4,94 daN
	H ₁	34,1

Dati tecnici

Motore: raffreddamento - alimentazione



Panda
gamma 2000

00.10

RAFFREDDAMENTO		
Circuito di raffreddamento	a circolazione di liquido refrigerante mediante pompa centrifuga, radiatore, ed elettroventilatore comandato da centralina controllo motore	
Comando pompa liquido refrigerante	mediante cinghia comando distribuzione	
 Innesto del ventilatore Comandato da centralina		90°-94°C
		85°-89°C
Termostato liquido refrigerante motore	inizio apertura	85°-89°C
	apertura massima	100°C
	corsa valvola	≥ 7,5 mm
Giuoco di montaggio fra le palette della girante a corpo pompa		0,4 + 0,9 mm
Pressione per controllo tenuta impianto	1,08 bar	
Controllo valvola di scarico su tappo serbatoio supplementare di espansione	0,98 bar	

ALIMENTAZIONE

Tipo	Iniezione-accensione elettronica integrata MPI – I.A.W. Weber-Marelli
Pompa	elettrica immersa nel serbatoio
Portata	≥ 110 l/h
Taratura regolatore di pressione carburante	3 bar

EMISSIONE DI CO ₂ ALLO SCARICO	Panda 	Panda 4x4 
	Emissione di CO ₂ secondo la direttiva 1999/100/CE	152 g/km

PARTICOLARI COMPONENTI L'IMPIANTO DI INIEZIONE INTEGRATA













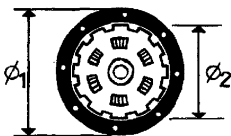

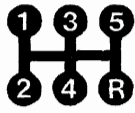
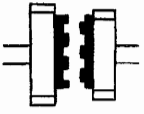

Unità elettronica di comando	M. Marelli IAW 59F
Corpo farfallato	M. Marelli 36SXFE1
Sensore di pressione e temperatura aria	M. Marelli T-PRT 05
Sensore di posizione valvola a farfalla	M. Marelli IPF 2C
Collettore carburante	M. Marelli CB 196
Elettroiniettori	M. Marelli IWP 116
Attuatore regime minimo	M. Marelli IB 01
Sensore di fase	Bosch PG 3.5
Sensore temperatura liquido refrigerante	Sylea 402.246.02
Sensore P.M.S.	Sylea CWM 02
Sonda Lambda n° 1 e 2	NTK OZA 532
Bobine di accensione	CHAMPION BAE 800 B
Candele	NGK BKR5EZ CHAMPION RC10YCC
Elettropompa carburante	MARWALL TTP359
Sensore di detonazione	NTK KNE 11
Relè principale impianto iniezione	Bitron
Elettrovalvola ricircolo vapori carburante	M.Marelli EC 2

00.18

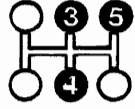

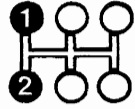

Valori in mm

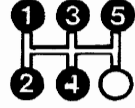
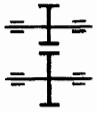
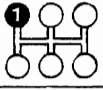
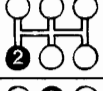
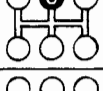
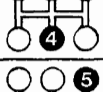
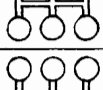
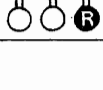



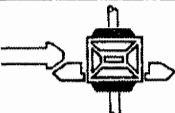













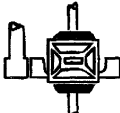

<p>Tipo</p>	 <p>monodisco a secco con cuscinetto a contatto</p>				
 <p>Meccanismo di innesto e disinnesto</p>	 <p>molla a disco</p>				
<p>Carico molla a disco</p>	<p>350 daNm</p>				
 <p>Disco condotto</p>	<table border="1"> <tr> <td data-bbox="861 985 1085 1097"> \varnothing_1 </td> <td data-bbox="1085 985 1428 1097"> <p>181,5</p> </td> </tr> <tr> <td data-bbox="861 1097 1085 1198"> \varnothing_2 </td> <td data-bbox="1085 1097 1428 1198"> <p>127</p> </td> </tr> </table>	\varnothing_1	<p>181,5</p>	\varnothing_2	<p>127</p>
\varnothing_1	<p>181,5</p>				
\varnothing_2	<p>127</p>				
 <p>Distanza tra pedale a fondo corsa e pedale in posizione di riposo</p>	<p>127 ±5</p>				
<p>Comando frizione</p>	<p>meccanico</p>				

		Panda  mpi	Panda 4x4  mpi
			
Tipo		C 526	
CAMBIO DI VELOCITÀ			
 Sincronizzatori	ad anello elastico (tipo Porsche)		
	ad anello libero		
 Ingranaggi	a denti dritti		
	a denti elicoidali		
 Rapporto ingranaggi		3,909	3,909
		2,158	2,056
		1,345	1,272
		0,974	0,978
		0,766	0,731
		3,818	3,727

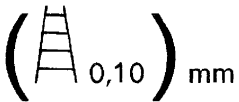
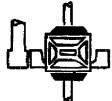





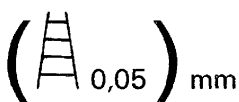



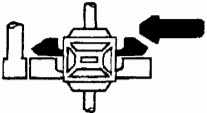

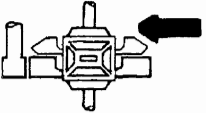

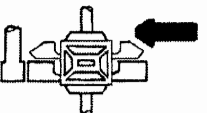

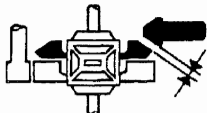

DIFFERENZIALE - RINVIO

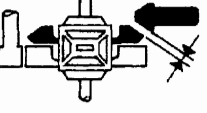
 Rapporto	 coppia cilindrica di riduzione	-	14/41 (2,929)
	 coppia cilindrica di riduzione	16/57 (3,562)	11/60 (5,455)

00.21-27

DIFFERENZIALE - RINVIO			Panda 1108 mpi	Panda 4 x 4 1108 mpi
	Rapporto coppia cilindrica di riduzione		16/57 (3,562)	11/60 (5,455)
	Rapporto sulle ruote		13,924	21,324
			7,868	11,215
			4,791	6,939
			3,469	5,335
			2,728	3,988
			13,600	20,331
	Cuscinetto scatola interna differenziale		 a rulli conici	
	Registrazione precarico cuscinetti		 mediante anelli	
  	Spessore anelli di ricambio		0,40 ÷ 1,00	
	Interferenza prescritta per ottenere l'esatto precarico cuscinetti	mm	cuscinetti scarichi = 0,12 cuscinetti carichi (350 daN) = 0,08	
	Precarico planetari-satelliti	mm	≤ 0,10	
	Registrazione interferenza planetari-satelliti		 mediante anelli	
  	Spessore anelli di ricambio		0,80 ÷ 1,15	

Panda 4 x 4  mpi

  <p>Rapporto coppia conica di rinvio</p>	<p>14/41 (2,929)</p>
  <p>daNm</p> <p>Coppia di rotolamento cuscinetti pignone conico di rinvio</p>	<p>0,08 ÷ 0,12</p>
  <p>Registrazione posi- zione pignone conico di rinvio</p>	 <p>mediante anelli</p>
  <p>mm</p> <p>Spessore anelli di ricambio</p>	<p>2,55 - 2,59 - 2,65 - 2,69 - 2,75 - 2,79 - 2,85 - 2,89 - 2,95 - 2,99 - 3,05 - 3,09 - 3,15 - 3,19 - 3,25 - 3,29 - 3,35</p>
 <p>mm</p> <p>Gioco fra pignone rinvio e corona</p>	<p>0,08 ÷ 0,15</p>
  <p>Registrazione gioco fra pignone rinvio e corona</p>	 <p>mediante anelli</p>
   <p>Registrazione precarico cuscinetti</p>	<p>mediante anelli</p>
   <p>0,10 mm</p> <p>Spessore anelli di ricambio precarico e registrazione gioco cuscinetti scatola interna differenziale</p>	<p>0,40 ÷ 1,00</p>

00.24





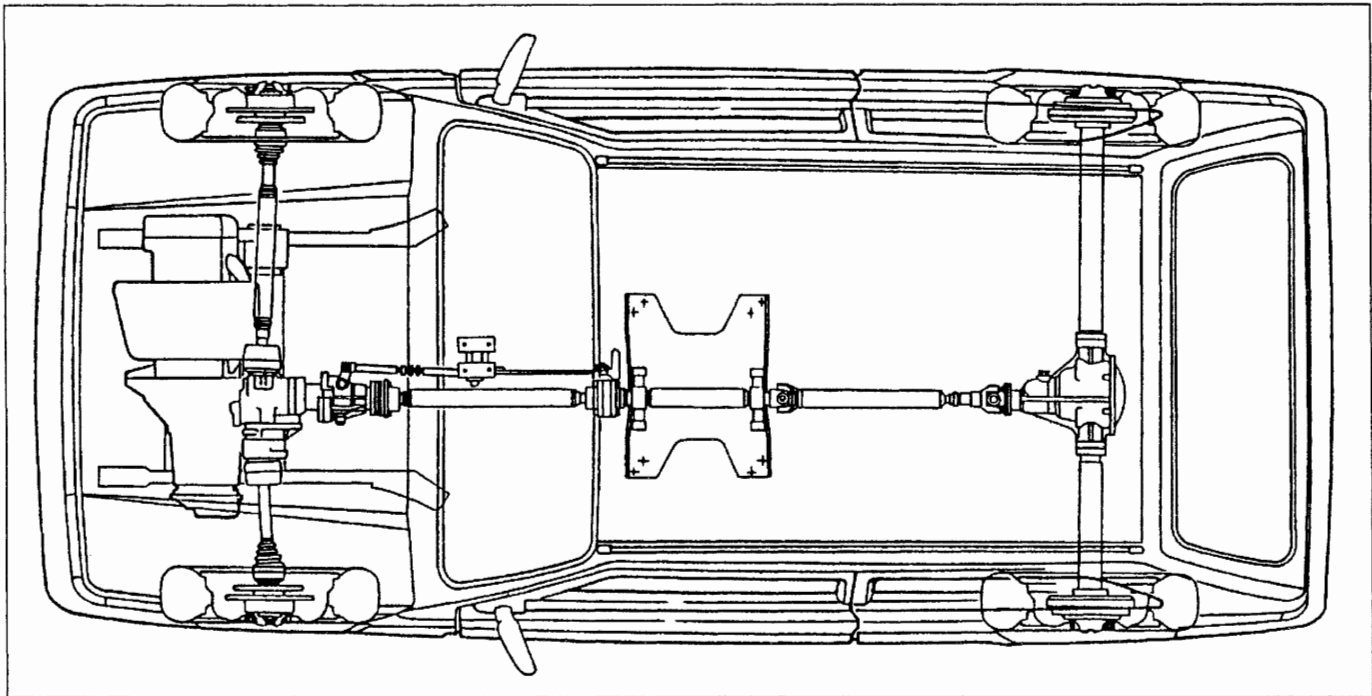





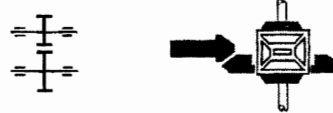
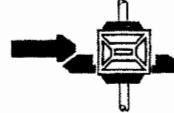
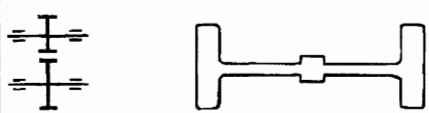
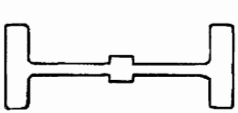









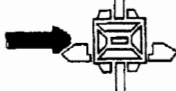

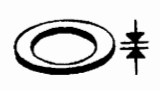
Panda 4 x 4 **1108** mpi

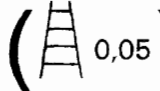
Tipo		in 3 tronchi
Supporti		2, con cuscinetti a sfere a tenuta stagna sul tronco centrale
Giunti omocinetici scorrevoli		2, sul tronco anteriore
Giunti cardanici		2, sul tronco posteriore
Giunto scanalato scorrevole		posteriore, sul tronco posteriore
Gioco radiale della crociera	mm	0,01 ÷ 0,04
Spessore anelli elastici di sicurezza per registrazione gioco radiale della crociera	mm	1,50 - 1,53 - 1,56 - 1,59 - 1,62
Gioco tra le scanalature del giunto scanalato	mm	0,175 ÷ 0,350

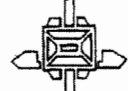

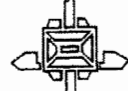
3X022DA01

Schema della trasmissione del motot sulle quattro ruote

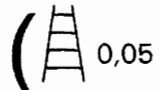









		 Panda 4x4	
		<p>14/41 (2,929)</p>	
<p>Rapporto coppia cilindrica di riduzione</p>			
		     	<p>21,324</p> <p>11,215</p> <p>6,939</p> <p>5,335</p> <p>3,988</p> <p>20,331</p>
<p>Rapporto sulle ruote</p>			
		<p>0,08 ÷ 0,12 da Nm</p>	
<p>Coppia di rotolamento cuscinetti pignone conico</p>			
		 <p>mediante anelli</p>	
<p>Registrazione posizione pignone conico</p>			
   <p>(0,05) mm</p>	<p>2,55 ÷ 3,35</p>		
<p>Spessore anelli di ricambio</p>			
		<p>daNm</p> <p>1 ÷ 6,8 daNm</p>	
<p>Coppia di rotolamento planetari satelliti</p>			
  	 <p>mediante anelli</p>		
<p>Registrazione coppia di rotol. planetari satelliti</p>			
   <p>(0,05) mm</p>	<p>2,75 ÷ 3,25</p>		
<p>Spessore anelli di ricambio</p>			

Dati tecnici

Ponte - Gruppo differenziale posteriore

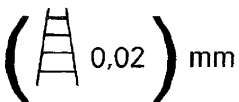
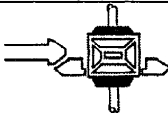
Panda
gamma 2000

00.27

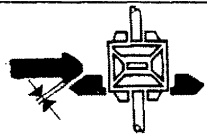
		 Panda 4x4
	Registrazione gioco tra pignone e corona	 mediante anelli
	Registrazione precarico cuscinetti	
  	Spessore anelli di ricambio precarico cuscinetti scatola interna differenziale	6,50 ÷ 7,50
	Cuscinetto scatola interna differenziale	 a rulli conici
 	Precarico cuscinetti (divaricamento supporti per scatola interna differenziale)	mm 0,040 ÷ 0,050
	Gioco fra pignone e corona	mm 0,08 ÷ 0,15









FRENI ANTERIORI

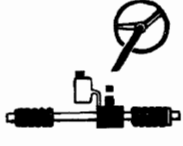
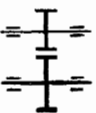

		Valori in mm	
<p>Disco</p>	<p>S</p> <p>consentito</p>	Ø	227
			10,60 ÷ 10,90
			9,35
			9
<p>Guarnizioni di attrito</p>	S	consentito	1,5
<p>Pinza</p>	Ø		48
<p>Cilindro maestro (pompa)</p>	Ø		19,05 (3/4")
<p>Servofreno</p>			Master-Vac da 158,5 mm (6") idropneumatico a depressione agente sulle quattro ruote
<p>Distanza del puntale comando stantuffo idraulico dalla piastra di appoggio cilindro maestro</p>	L		0,825 ÷ 1,025

FRENI POSTERIORI

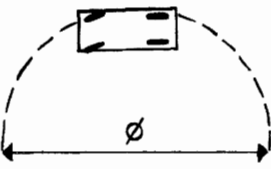
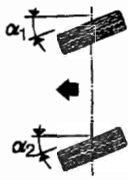
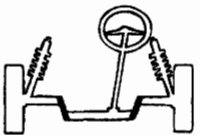
<p>Tamburo</p>	<p>Ø</p> <p>consentito</p>		185,23 ÷ 185,54
			186,33
			186,83
<p>Ganasce</p>	S	consentito	1,5
<p>Cilindretti</p>	Ø		19,05 (3/4")
	Regolatori di pressione		agente sulle ruote posteriori
	Rapporto (di riduzione)		0,60

00.41

		 Panda		 Panda 4x4	
Tipo		 a cremagliera			
 Rapporto		 rotazione volante		3,8 giri	
		 corsa cremagliera		130 ± 1,5 mm	
		Diametro minimo di sterzata		m	
				9,45	
				9,22	
 Angolo di sterzata		ruota esterna α_1		31° ± 1°30'	
		ruota interna α_2		33° 30'	
 Piantone sterzo		 con 2 giunti cardanici			



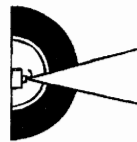

RUOTE	MOTORIZZAZIONE	1108			
		Panda	Panda 4x4		
 	Pneumatico	tipo	135 R13-69T	155/65 R13"-73T (▲)	145 R13"-74Q
	anteriori	medio carico	2,0 bar	2,2 bar	2,0 bar
		pieno carico	2,2 bar	2,2 bar	2,0 bar
	posteriori	medio carico	2,0 bar	2,2 bar	2,0 bar
		pieno carico	2,2 bar	2,2 bar	2,0 bar
	Cerchio	tipo	4,00 B 13"		4,00 B 13"

(▲) A richiesta per alcune versioni

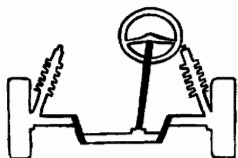

a vettura scarica (*)

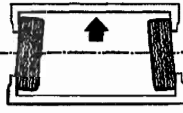
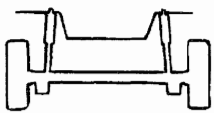
ASSETTO RUOTE

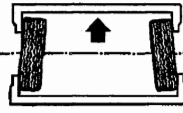

 sospensione anteriore	inclinazione (**)		1° ±30'	2°30' ±30'
	incidenza (**)		-1°15' ±30'	2° ±30'
	convergenza		0 ±1 mm	0 ±1 mm
 sospensione posteriore	inclinazione (**)		-	-
	convergenza (**)		-	-

(*) Con pneumatici gonfiati alla pressione prescritta e vettura in ordine di marcia

(**) Angoli non registrabili

00.44

Sospensione anteriore a ruote indipendenti con bracci oscillanti inferiori e montanti telescopici costituiti ciascuno dal montante in lamiera collegato rigidamente all'ammortizzatore idraulico a doppio effetto. Molle ad elica e tasselli di tamponamento coassiali con gli ammortizzatori. Snodi che non richiedono ingranaggio (for-life).



Molle ad elica				
		Panda	Panda Van	Panda 4x4
Numero di ordinazione		7731039	7635774	5975433
Diametro del filo	mm	9,6 ±0,05	9,7 ±0,05	10,6 ±0,05
Numero spire utili		6,75	5,75	8,5
Senso dell'elica		destrorso	destrorso	destrorso
Altezza molla libera		mm 354	mm 330	mm 364
Altezza molla sotto un carico di:	220 ±9 daN	mm 213	–	–
	208,5 ±8 daN	–	mm 213	–
	241 ±10 daN	–	–	mm 231
Le molle sono suddivise in due categorie, identificabili mediante contrassegno:				
giallo (1) quelle aventi sotto un carico di:	220 daN un'altezza di mm	>213	–	–
	208,5 daN un'altezza di mm	–	>213	–
	241 daN un'altezza di mm	–	–	>231
verde (1) quelle aventi sotto un carico di:	220 daN un'altezza di mm	≤213	–	–
	208,5 daN un'altezza di mm	–	≤213	–
	241 daN un'altezza di mm	–	–	≤231

(1) Il montaggio deve effettuarsi con molle appaiate dello stesso contrassegno

Ammortizzatori

Tipo: telescopico, a doppio effetto		BOGE - WAY - ASSAUTO		
Numero di ordinazione		7720251	5957955	7695195
Aperto (inizio tamponamento)	mm	430 ±2	430 ±3	440 ±2
Chiuso (ferro contro ferro)	mm	282 ±2	282 ±3	299 ±2
Corsa	mm	148	148	141

Sospensione posteriore a ponte rigido di struttura tubolare e di forma a omega (Ω) con incernieramento centrale e bracci di reazione longitudinali; molle elicoidali e ammortizzatori telescopici a doppio effetto.

		 Panda	 Panda Van
Molle ad elica			
Numero di ordinazione		46768802	7557202
Diametro del filo	mm	10,2±0,05	11,7±0,05
Numero spire utili		4	4,5
Senso dell'elica		destroso	destroso
Altezza molla libera	mm	288	258,7
Altezza molla sotto un carico di:	257 ±10 daN	mm	170
	265 ±10 daN	mm	-
		-	170
Le molle sono suddivise in due categorie, identificabili mediante contrassegno:			
giallo (1) quelle aventi sotto un carico di:	257 daN un'altezza di mm	>170	-
	265 daN un'altezza di mm	-	>170
verde (1) quelle aventi sotto un carico di:	257 daN un'altezza di mm	≤170	-
	265 daN un'altezza di mm	-	≤170

(1) Il montaggio deve effettuarsi con molle appaiate dello stesso contrassegno

Ammortizzatori

Tipo: telescopico, a doppio effetto (a gas a bassa pressione)		BOGE - WAY - ASSAUTO	
Numero di ordinazione		7720252	7600789
Aperto (inizio tamponamento)	mm	420 ±3	420 ±3
Chiuso (ferro contro ferro)	mm	252 ±3	252 ±3
Corsa	mm	168	168

00.44

Sospensione posteriore ad assale rigido tubolare collegato alla scocca con due balestre longitudinali a tre foglie e tasselli elastici.

Ammortizzatori idraulici telescopici a doppio effetto.

Molla a balestra

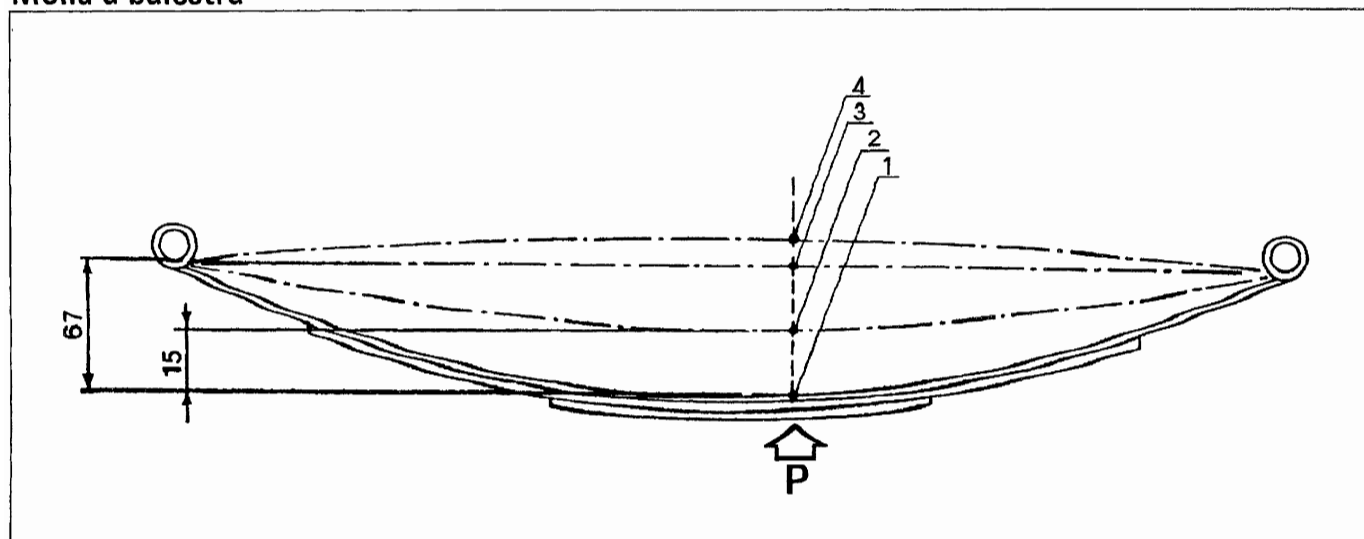

3X030DA01

Posizione		Carico P daN	Freccia mm	Cedimento elastico a partire dalla pos. 1 mm	Flessibilità mm/100 daN
1	Inizio controllo flessibilità	100	-	-	45,4 ± 3
2	Carico di riferimento	134	42,5 ± 3	15 ± 1	
3	Fine controllo flessibilità	250	-	67 ± 5	
4	Carico di tamponamento massimo	355	-	115 ± 9	

Ammortizzatori

Tipo: telescopico a doppio effetto		Way Assauto
Aperto (inizio tamponamento)	mm	340 ± 2
Chiuso (ferro contro ferro)	mm	195 ± 3
Corsa	mm	145



MOTORE DI AVVIAMENTO	M. Marelli E80E-0,8kW-12V
ALTERNATORE	DELPHI CS121D – 14V – 60A DENSO A115I – 14V – 33/60A
REGOLATORE DI TENSIONE (elettronico incorporato)	19009747 Chip RTM 200.01
BATTERIA	40Ah-12V-200A
SISTEMA DI ACCENSIONE	accensione integrata con sistema di iniezione MPI I.A.W. Weber Marelli
ROCCHETTO DI ACCENSIONE	Champion BAE 800B
CANDELE	Champion RC10YCC NGK BKR5EZ

00.55

MOTORE D'AVVIAMENTO



Tipo	M. Marelli E80E-12V-0,8kW	
Tensione	V	12
Potenza nominale	kW	0,8
Rotazione, lato pignone	destrorsa	
Poli	4	
Eccitazione	avvolgimento in serie	
Innesto	a ruota libera	
Comando	elettromagnetico	
Gioco assiale dell'albero indotto	mm	0,1÷0,4
Dati per la prova al banco		
Prova di funzionamento (*):		
corrente	A	170
velocità	1/min	1850
tensione	V	9,4
coppia sviluppata	daNm	0,42
Prova di spunto (*):		
corrente	A	330÷350
tensione	V	6,7÷7,1
coppia sviluppata	daNm	≥0,9
Prova a vuoto (*):		
corrente	A	30÷40
tensione	V	11,5
velocità	1/min	≥7500
Teleruttore Resistenza dell'avvolgimento (*)	} strappo Ω ritegno Ω	0,33÷0,37
		1,52÷1,72
Lubrificazione		
Scanalature interne dell'innesto e boccole albero	VS ⁺ SAE 10W	
Manicotto d'innesto e relativo disco intermedio	TUTELA MR3	

(*) Dati rilevati alla temperatura ambiente di 20°C.

NOTA In sede di revisione non è richiesta la ribassatura dell'isolante tra le lamelle del collettore.

MOTORE AVVIAMENTO - CURVE CARATTERISTICHE

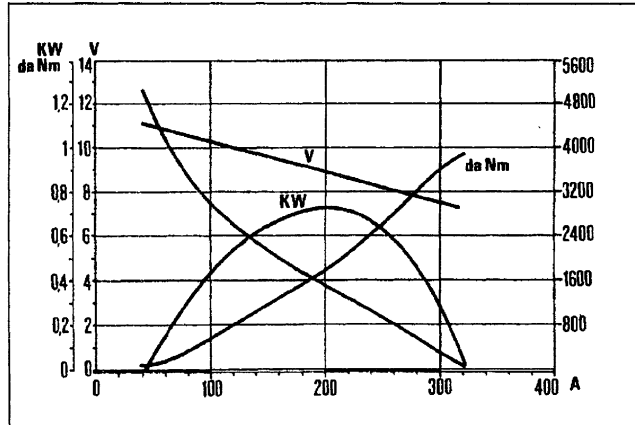

3X033DA01

M. Marelli E80E-12V - 0,8kW

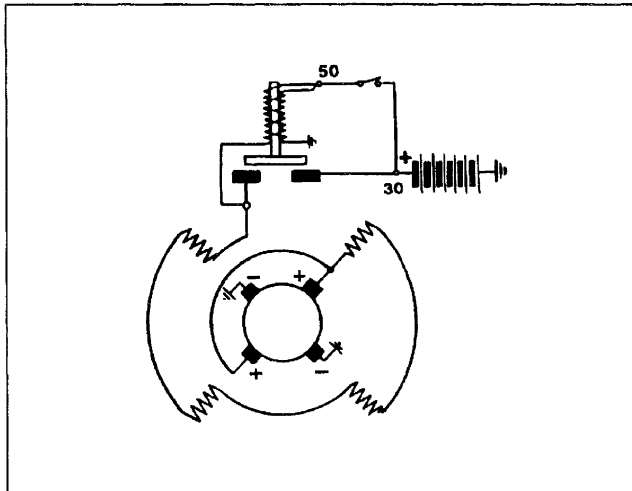

3X033DA02

Schema elettrico del motore di avviamento M. Marelli E80E-12V-0,8kW

00.55



ALTERNATORE

Tipo e sigla		DELPHI CS121D - 14V - 60A	DENSO A115I - 14V - 33/60A
Tensione nominale dell'impianto	V	14	
Corrente massima	A	65	60
Velocità di inizio carica a caldo	1/min	1800	1800
Corrente erogatore su batteria a 7000/min ed a regime termico	A	65	60
Resistenza avvolgimento induttore tra i due anelli collettore (*)	Ω	1,8±5%	2,8±5%
Senso di rotazione (visto dal lato comando)		orario	
Diodi raddrizzatori di potenza		a ponte precostituito	

(*) Dati rilevati alla temperatura ambiente di 20°C.

REGOLATORE DI TENSIONE

Electronico incorporato nell'alternatore	tipo	19009747 Chip	RTM 200.01
Velocità alternatore per controllo	1/min	7000	
Correttore per stabilizzazione termica	A	-	
Corrente di controllo	A	-	
Tensione di regolazione (*)	V	14,00 ÷ 14,63	14,05 ÷ 14,35

(*) Dati rilevati alla temperatura ambiente di 20°C.

BATTERIA

Tensione nominale	V	12
Capacità (alla scarica di 20 ore)	Ah	40

Schema elettrico degli alternatori

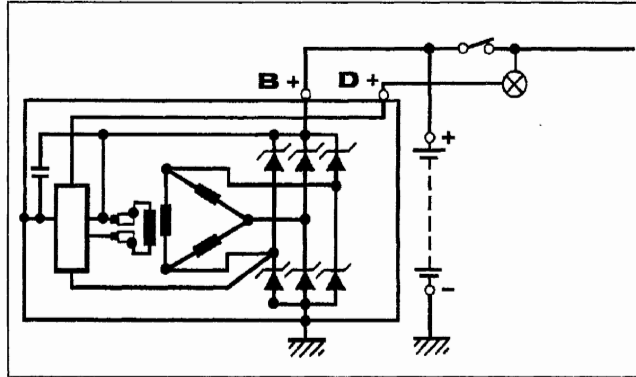

3X035DA01

DELPHI CS121D - 14V - 60A
DENSO A115I - 14V - 33/60A

Curve caratteristiche dei regolatori di tensione

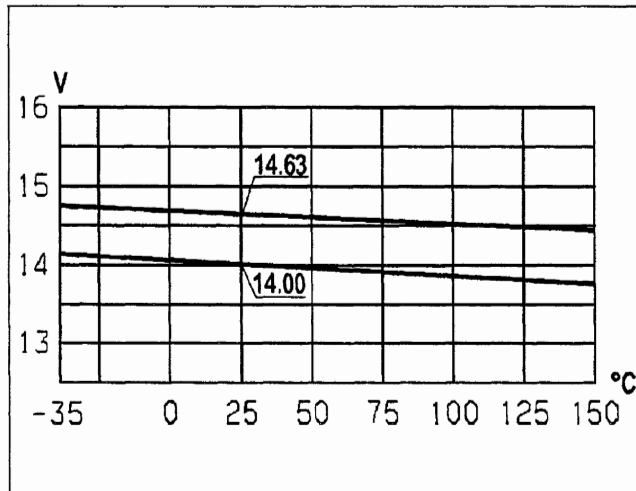

3X035DA02

19009747 Chip

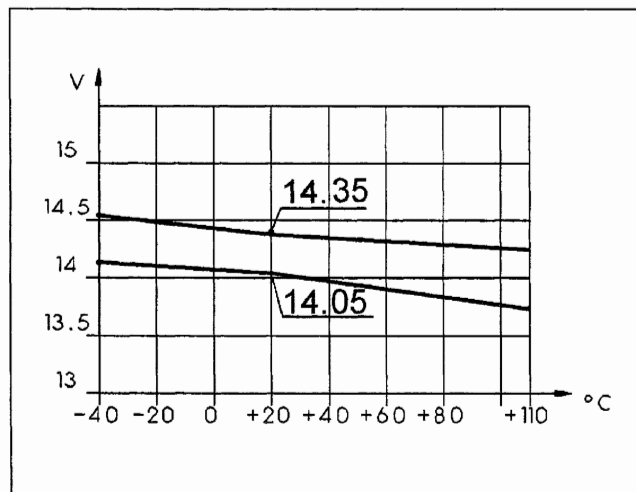

3X035DA03

RTM 200.01

00.55**INIEZIONE – ACCENSIONE ELETTRONICA STATICA**

Tipo	Accensione elettronica statica integrata con il sistema di iniezione
Sigla	IAW 59F
Ordine di accensione	1 - 3 - 4 - 2

ROCCHETTO CON 2 PRESE DI ALTA TENSIONE

Tipo	Champion
Sigla	BAE 800 B
Resistenza ohmica del primario a 20°C	Ω 0,495÷0,605
Resistenza ohmica del secondario a 20°C	Ω 6660÷8140

SENSORE DI PUNTO MORTO SUPERIORE E NUMERO DI GIRI

Tipo e sigla	Sylea CWM 02
Resistenza avvolgimento sensore	Ω 1134÷1386
Distanza (traferro) tra il sensore e dente puleggia albero motore	mm 0,5 ÷ 1,5

ANTICIPO SU MOTORE

Con motore al minimo	$10^{\circ} \pm 5^{\circ}$
----------------------	----------------------------

CANDELE

Tipo e sigla	Champion	RC10YCC
	NGK	BKR5EZ
Filettatura di attacco sul motore		M14 x 1,25
Distanza fra gli elettrodi	mm	0,85÷0,95