

pag.

GENERALITÀ

- Esterno vettura	1
- Particolarità interno vettura	3
- Particolarità esterno/interno vettura	4
- Particolarità interno vettura	5
- Ubicazione su vettura dei dati di identificazione	6
- Ubicazione su vettura dei dati di identificazione - Pesì	7
- Dimensioni	8
- Prestazioni - Consumo carburante	9
- Colori	10
- Optinals	11
- Rifornimenti	12
- Caratteristiche di lubrificanti	13

DATI TECNICI**MOTORE**

- Dati caratteristici	14
- Curve caratteristiche	15
- Basamento e organi del manovellismo	16
- Testa cilindri e organi della distribuzione	20
- Lubrificazione	23
- Raffreddamento - Alimentazione	24

FRIZIONE	26
----------	----

CAMBIO E DIFFERENZIALE	27
------------------------	----

ALBERO DI TRASMISSIONE	30
------------------------	----

PONTE - GRUPPO DIFFERENZIALE POSTERIORE	30
--	----

FRENI	33
-------	----

STERZO	34
--------	----

RUOTE	35
-------	----

SOSPENSIONE ANTERIORE	36
-----------------------	----

SOSPENSIONE POSTERIORE	37
------------------------	----

IMPIANTO ELETTRICO	39
--------------------	----

- Avviamento	40
- Ricarica	42
- Accensione	44
- Accensione elettronica	44



00.0

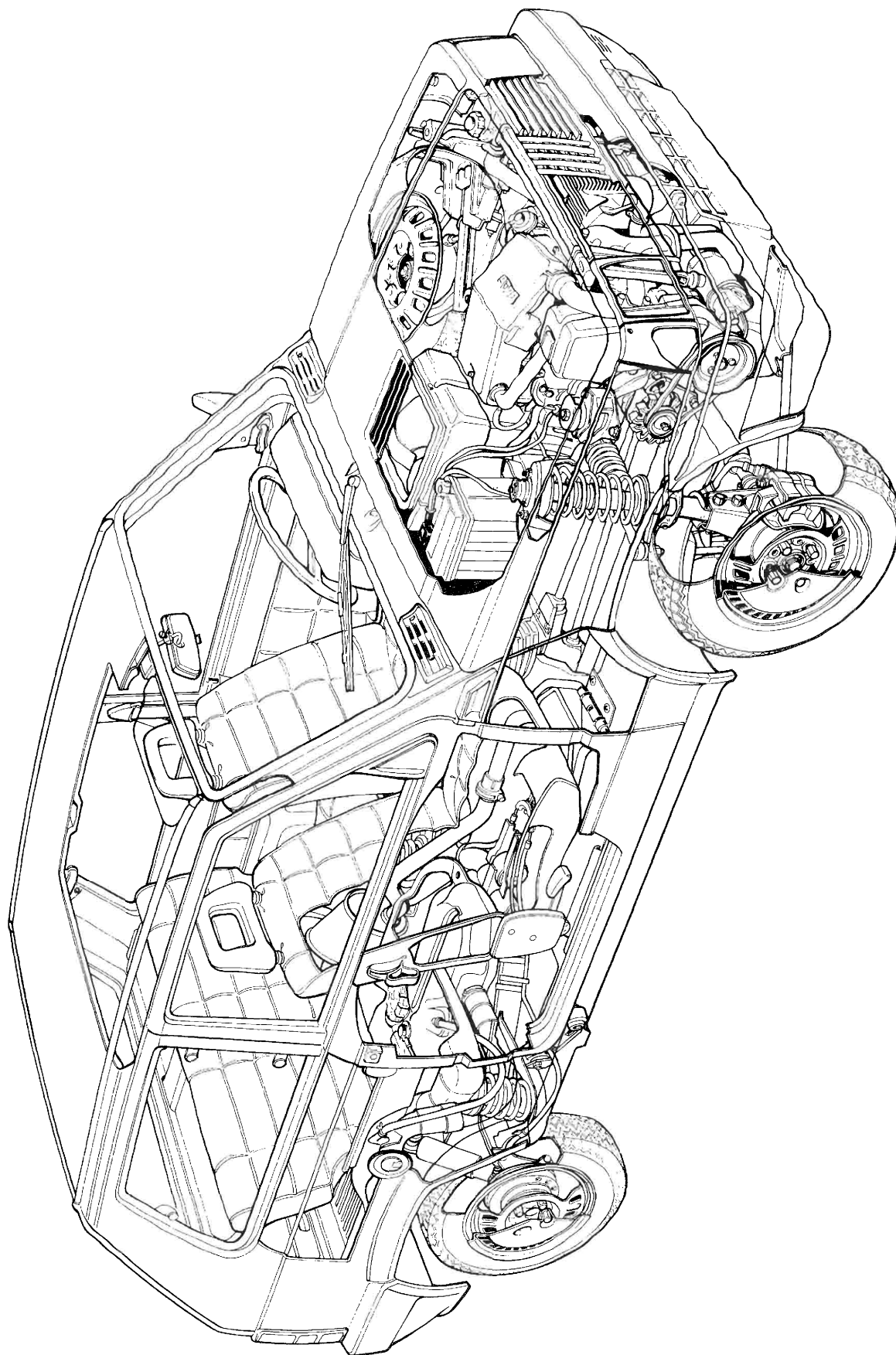

Disposizione degli organi meccanici sulla vettura

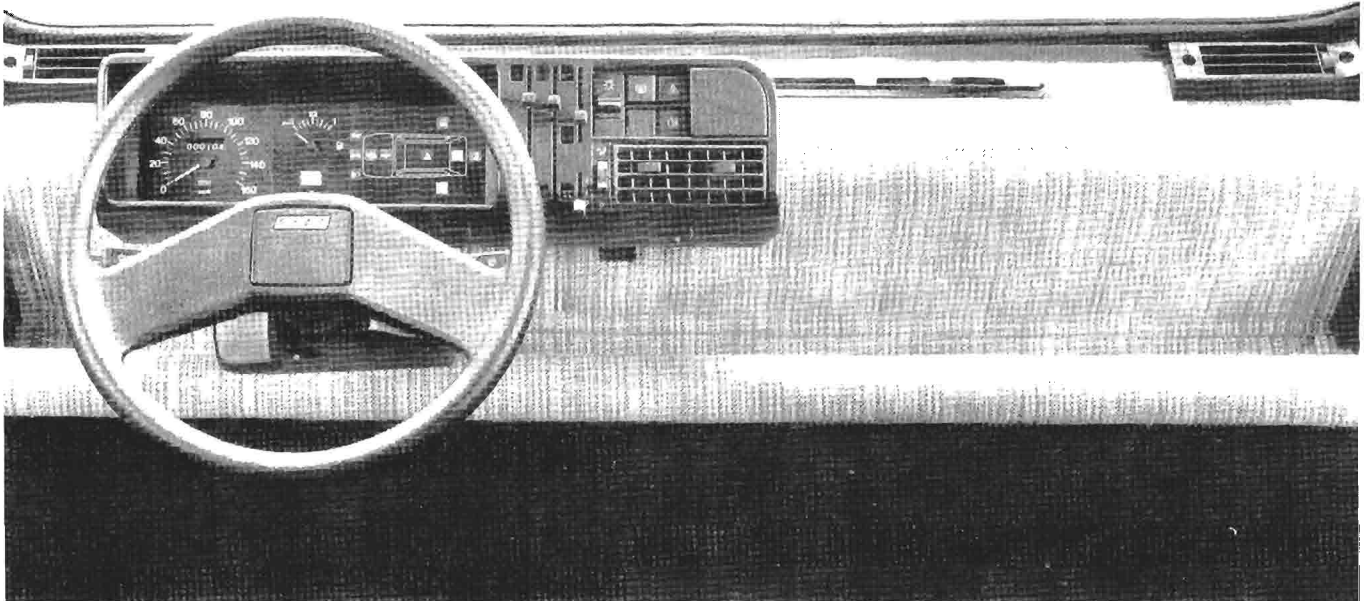

Plancia portastrumenti per versioni L - CL

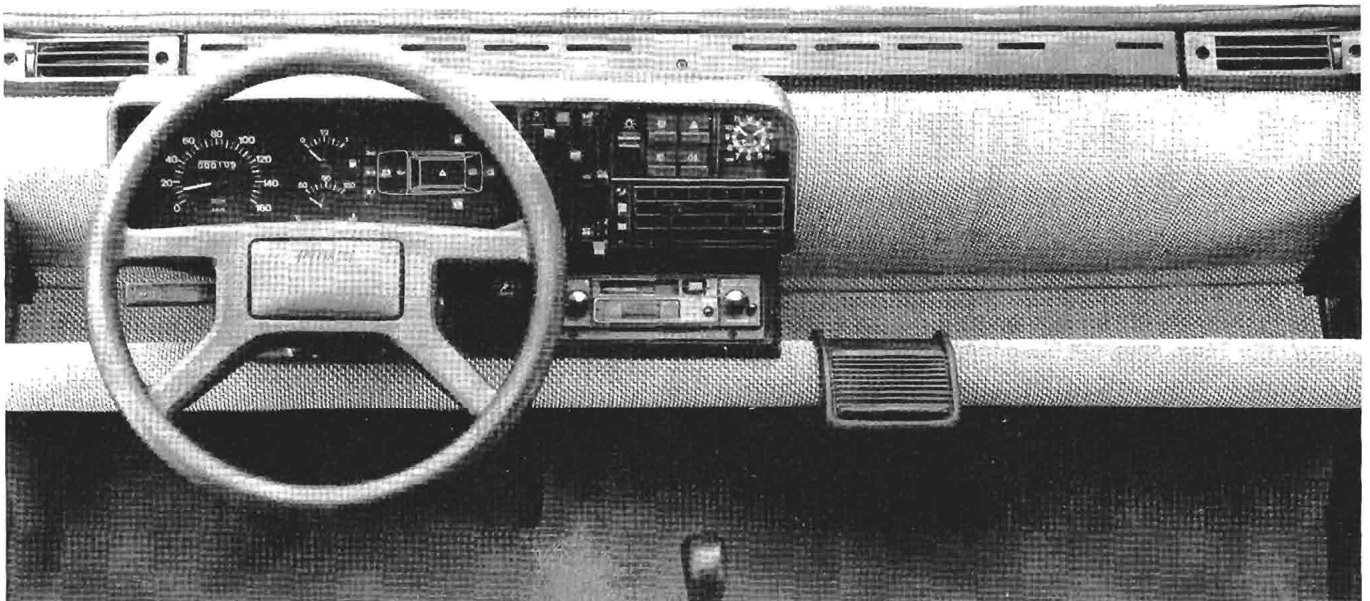

Plancia portastrumenti per versioni S

00.0



Versione Panda 4x4

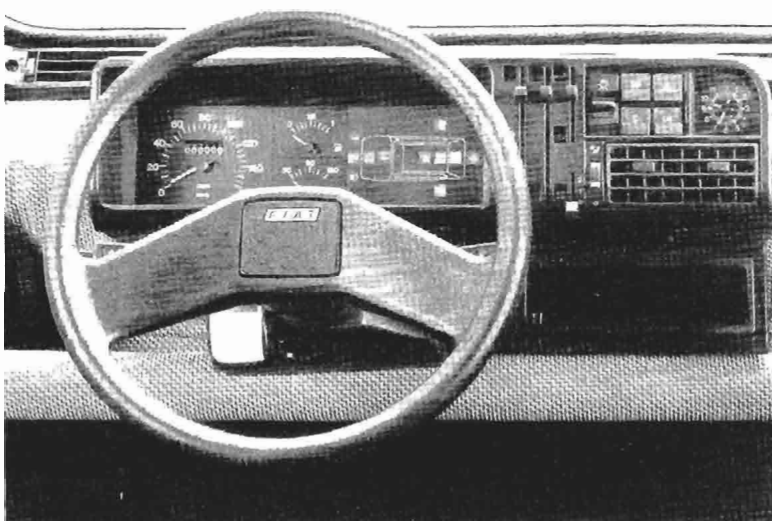

Plancia portastrumenti della versione Panda 4x4

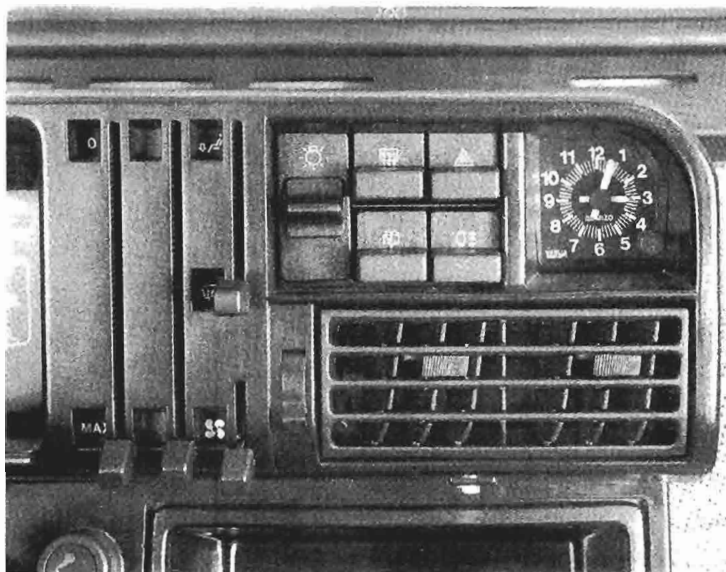

Comandi per ventilazione e riscaldamento interno vettura

Plancetta portainterruttori e orologio analogico al quarzo



Particolare del comando dello specchio retrovisore esterno dall'interno vettura



Sedili anteriori con dispositivo di sbloccaggio e ribaltamento dello schienale

00.0

	AUTOTELAIO	MOTORE	VERSIONE	3 porte	CAMBIO	
					4 marce	5 marce
Panda 750	ZFA 141 A 000	156 A4.000	141 AA 43 A	●	●	
			141 AA 53 A	●		●
156 A2.000		141 AB 43 A	●	●		
		141 AB 53 A	●		●	
Panda 4x4		156 A3.000	141 AB 53 B	●		●



Tipo e numero di identificazione dell'autotelaio

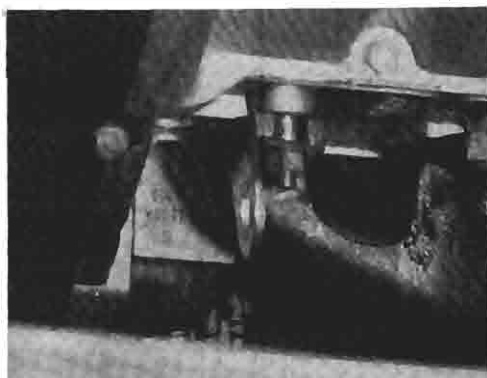
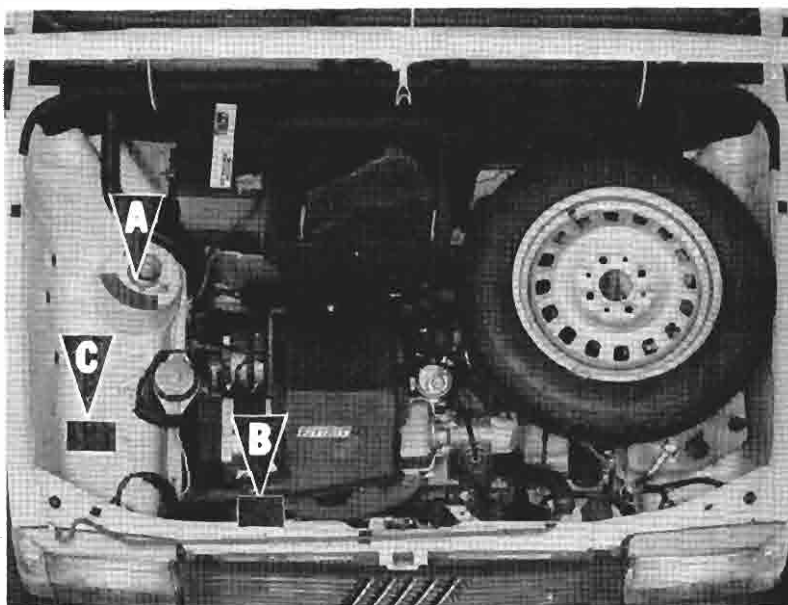



Tipo e numero del motore in prossimità del filtro olio a cartuccia

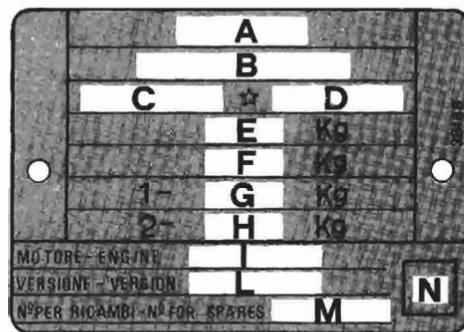









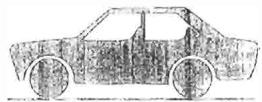
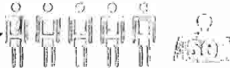

- A. Nome del costruttore
- B. Numero di omologazione
- C. Codice di identificazione del tipo di veicolo
- D. Numero progressivo di fabbricazione dell'autotelaio
- E. Peso massimo autorizzato del veicolo a pieno carico
- F. Peso massimo autorizzato del veicolo a pieno carico piú rimorchio
- G. Peso massimo autorizzato sul primo asse (anteriore)
- H. Peso massimo autorizzato sul secondo asse (posteriore)
- I. Tipo del motore
- L. Codice versione carrozzeria
- M. Numero per ricambi
- N. Spazio riservato per vetture Diesel (valore corretto del coefficiente di assorbimento fumosità)

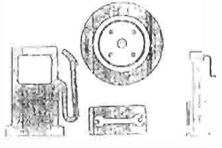

 Targhetta riassuntiva di marcatura (normativa C.E.E.)

PESI (valori espressi in kg)

		
--	---	---

	+ 400 	700	790
	+  	1100	1190
	+  	515	566
Vettura in ordine di marcia		585	624
	+  	475	524
		625	666
		800	900

00.o

Versioni L - CL - Super

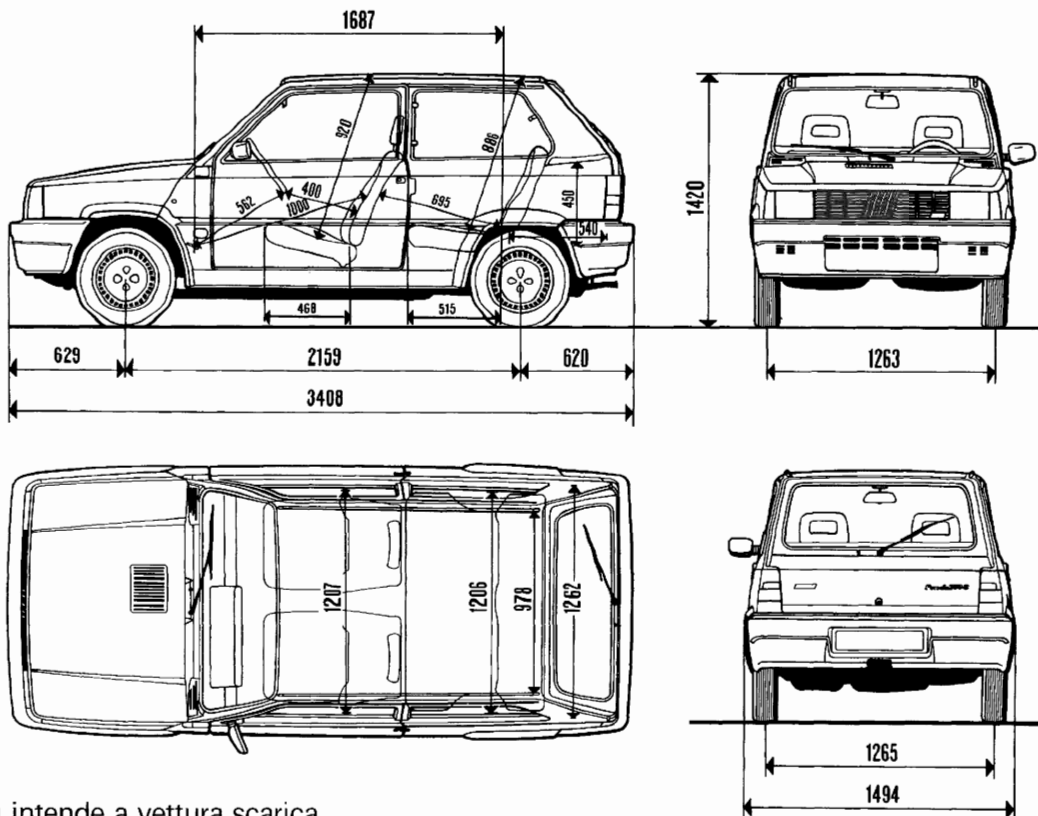





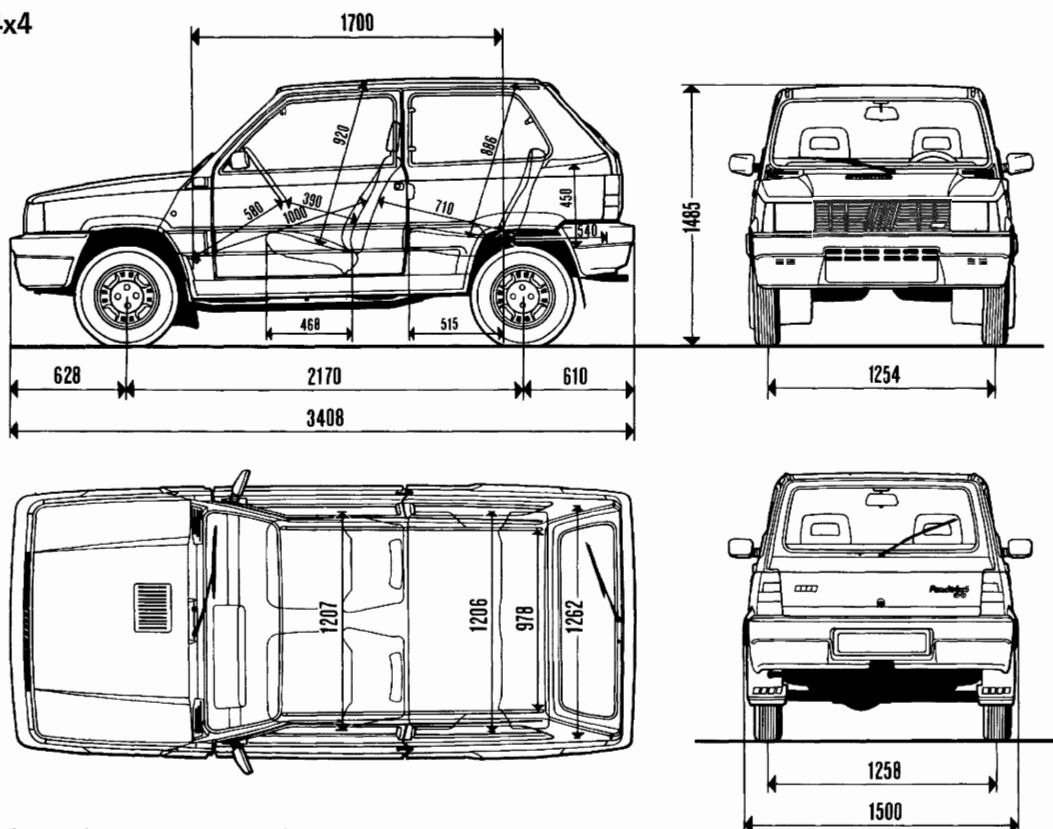





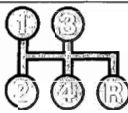

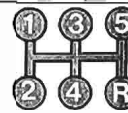







L'altezza si intende a vettura scarica

Versione 4x4



L'altezza si intende a vettura scarica

MOTORIZZAZIONE			
CAMBIO			

<p>Velocità km/h</p> 		35	36	29	
		66	69	55	
		100	105	85	
		125	140	115	
		-	120	135	130
		36	38	31	
<p>Pendenza a massimo carico</p> 		28,5	35,5	36 43*	
		13,8	18,5	20	
		8,1	11	12	
		4,9	6,5	8	
		-	4,5	5,5	5,5
		27,5	35,5	36 39*	
<p>Consumo carburante secondo norme ECE (litri/100 km)</p>  	Percorso urbano (A)	6,2	6,2	6,3	7
	Velocità costante 90 km/h (B)	5	4,6	4,6	6,1
	Velocità costante 120 km/h (C)	-	-	6,5	8,2
	Consumo medio (proposta CCMC) A + B + C 3	5,6	5,4	5,8	7,1

* Con trazione posteriore inserita

00.0

ALLESTIMENTO	L	CL	SUPER	4x4
--------------	---	----	-------	-----

COLORI ESTERNO PASTELLO	MATERIALI E COLORI SEDILI						
	Finta pelle	Tessuto/ F.Pelle *	Tessuto/F.Pelle	Tessuto/F.Pelle		Finta pelle	Tessuto/ F.Pelle
	Azzurro rigato 204	Mixer beige 855	Tequila grigio 366	Panama bleu 344	Panama beige 355	Morea nero 208	Panama beige 355
Rosso Garanza 111	●	●	●		●		
Bianco Corfù 224	●	●	●	●		●	●
Blu Lord 438	●	●	●	●			
Azzurro 485	●	●	●	●			
Nero 601	●	●	●		●		
Grigio Oslo 626	●	●	●		●	●	●
Rosso Corsa 854	●	●	●		●	●	●

* Solo a richiesta

COLORI ESTERNI METALLIZZATI (OPTIONALS)

Turchese 468					●		
Beige Visone 583					●		
Grigio chiaro 683				●		●	●

OPTIONALS
(validi solo per il mercato italiano)

ALLESTIMENTO	L	CL	SUPER	4x4
Cinture di sicurezza anteriori	●	●	●	●
Lunotto termico	●	●	●	●
Luci emergenza	●	●	●	●
Cristalli posteriori apribili a compasso		●	●	●
Tergilavalunotto		●	●	●
Sedili anteriori reclinabili		●	●	●
Appoggiatesta sedili anteriori		●	●	●
Cappelliera		●	●	●
Coppe ruote integrali			●	
Termometro acqua			●	●
Specchio retrovisore esterno regolabile dall'interno			●	●
Accendisigari			●	●
Cassetto portaradio			●	●
Cambio a 5 marce			●*	●
Tetto apribilee		▲	▲	▲
Orologio analogico			▲	▲
Cristalli atermici			▲	▲
Parabrezza laminato				●
Verniciatura metallizzata			▲	▲
Pneumatici maggiorati 155 SR 13"			▲	
Interno in panno	▲	●	●	●**
Specchio retrovisore esterno supplementare regolabile dall'interno				●











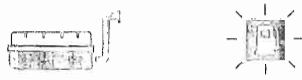



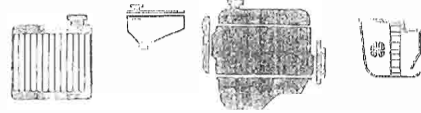

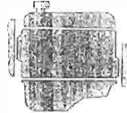





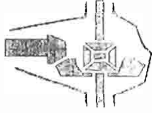





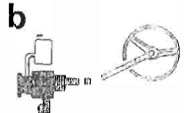

● di serie

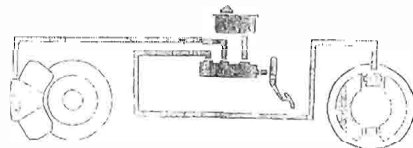
▲ a richiesta

* a richiesta per versione 750

** in alternativa a finta pelle Morea nero



00.0

Rifornimento	Parte da rifornire	Quantità				
		dm ³	(kg)			
 Benzina N.O. (98-100)		 40	-			
		 35	-			
 50% + 	 Capacità totale impianto di raffreddamento	5,20	-			
 VS ⁺ Superstagionale (SAE 10 W) (SAE 20 W) (SAE 30) (SAE 40) VS ⁺ Supermultigrado (SAE 15 W/40)	Capacità totale 	3,88	3,45			
	Capacità parziale (sostituzione periodica) * 	3,75	3,33			
 a = TUTELA ZC 90  b = TUTELA GI/A 		a	2,40	2,15		
		b	-	-		
 TUTELA W 140/M DA	a 	b  	a	-	1,20	
		Autobloccante	b	-	-	
 a e b = TUTELA GI/A c = TUTELA W 90/M DA  d = K 854	a 	c 	d 	a	-	-
	b 			b	-	-
				c	-	-
				d	-	0,1
 TUTELA DOT 3	Capacità totale 	0,39	0,39			
 + 	 3%  ~ -10°C 50% ~ -20°C 100%		 	3,50	-	





* La quantità di olio necessaria per la sostituzione periodica (filtro escluso) è di 3,35 dm³ (3 kg)

Denominazione prodotto	Descrizione Designazione internazionale	Applicazione
VS ⁺ Superstagionale	SAE 40	Temperatura 0°C ÷ >35°C
	SAE 30	Temperatura 0°C ÷ <35°C
	SAE 20 W	Temperatura minima -15°C ÷ 0°C
	SAE 10 W	Temperatura minima sotto -15°C
	SAE 15 W/40	Temperatura -15°C ÷ >35°C
VS Turbo Synthesis SAE 15 W/40	Olio detergente con base sintetica per motori a benzina. Servizio API "SE". Soddisfano la specifica MIL-L-46152. Superano le specifiche Europee CCMC.	Temperatura -15°C ÷ >40°C
VS Diesel	SAE 40	Temperatura 0°C ÷ 50°C
	SAE 30	Temperatura -5°C ÷ 30°C
	SAE 20 W	Temperatura -15°C ÷ 15°C
	SAE 10 W	Temperatura sotto -15°C
VS Diesel Supermultigrado	Olio per motori Diesel. Servizio API "CD". Soddisfano la specifica MIL-L-2104 C.	Temperatura -20°C ÷ 40°C
TUTELA ZC 90	Olio SAE 80 W/90 non EP, per cambi di velocità meccanici, contenente additivi antiusura.	Cambi e differenziali non ipoidi
TUTELA W 140/M DA	Olio SAE 85 W/140 EP speciale per differenziali normali ed autobloccanti. Soddisfa la specifica MIL-L-2105 C.	Differenziali ipoidi Differenziali autobloc. Scatole sterzo
TUTELA GI/A	Olio per trasmissioni automatiche tipo "DEXRON II".	Cambi di velocità autom. Idroguidi
TUTELA JOTA 1	Grasso a base di saponi di litio, consistenza N.L.G.I.N.1	Ingrassaggio della vettura tranne gli organi particolarmente esposti all'acqua richiedenti grassi specifici
TUTELA MRM2	Grasso al bisolfuro di molibdeno a base di saponi di litio idrorepellente, consistenza N.L.G.I.N.2	Giunti omocinetici
TUTELA MR3	Grasso a base di saponi di litio, consistenza N.L.G.I.N.3	Cuscinetti mozzi ruote tiranti sterzo, organi vari
TUTELA DOT 3	Liquido per freni idraulici DOT 3, risponde alle norme F.M.V.S.S n. 116	Freni idraulici e comandi idraulici frizione
K 854	Grasso a base di saponi di litio, consistenza N.L.G.I. 000 contenente bisolfuro di molibdeno	Scatole sterzo a cremagliera
SP 349	Grasso speciale a base di olio di ricino e sapone di sodio con grafite e bisolfuro di molibdeno, è compatibile con liquido freni e con le guarnizioni di gomma del circuito freni	Correttore di frenata Boccola correttore di frenata comando tirantino a barra
Liquido Autofà DP1	Liquido detergente a base di alcool	Da impiegarsi puro o diluito negli impianti lavacristalli e tergi
Liquido Paraflu ¹¹ FIAT	Protettivo con azione anticongelante per impianti di raffreddamento a base di glicole monoetilenico inibito	Circuiti di raffreddam. Percentuale di impiego 35% fino a -25°C 50% fino a -35°C

00.10

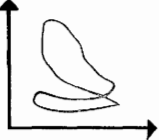
		
---	---	---

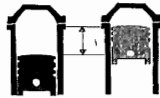
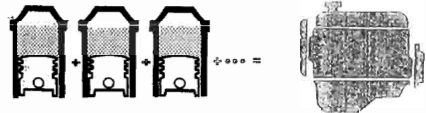
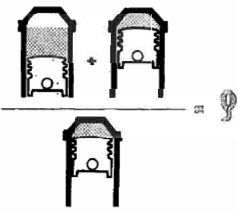
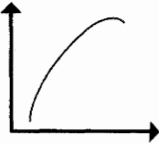
DATI CARATTERISTICI

	Ciclo		OTTO 4 tempi		
	Numero cilindri		4 in linea		
	Canna cilindro (alesaggio)	mm	65	70	
	Corsa	mm	58	64,9	
	Cilindrata	cm ³	769,8	999	
	Rapporto di compressione		9,4 ± 0,2	9,8 ± 0,2	
	Potenza massima CEE	kW (CV)	25 (34)	33 (45)	37 (50)
		1/min	5250	5000	5500
	Coppia massima CEE	daNm (kgm)	5,7 (5,8)	8,0 (8,2)	7,8 (8,0)
		1/min	3000	2750	3500

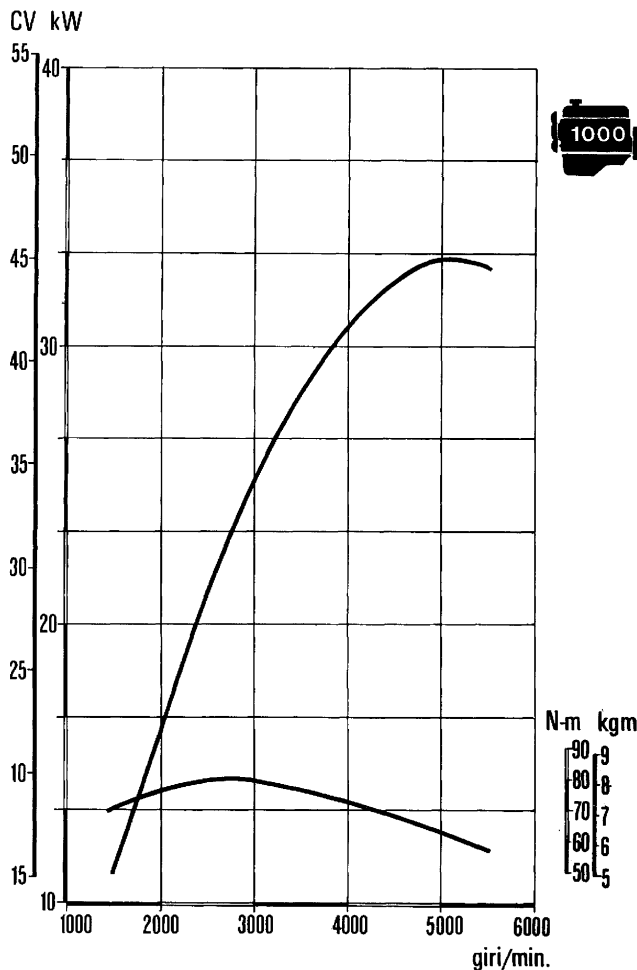
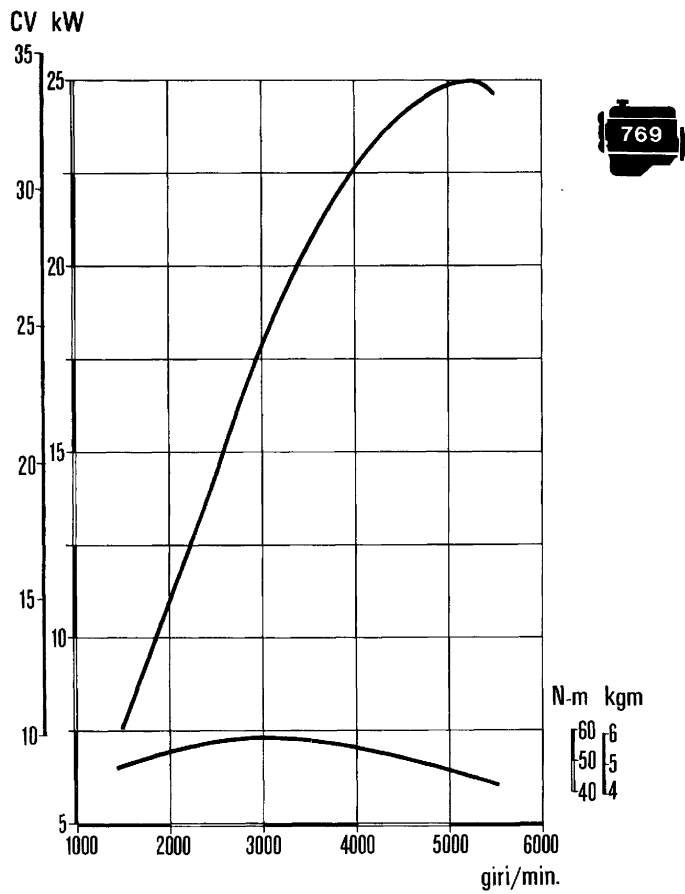

Curve caratteristiche dei motori rilevati con il metodo CEE

Le curve di potenza illustrate sono quelle ottenibili a motori revisionati e rodati, senza ventilatori, con silenziatori di scarico e filtri aria, al livello del mare.

Cicli di prova al banco dei motori revisionati

Nella prova al banco dei motori revisionati, non è consigliabile portare i motori a regime massimo, ma attenersi ai dati prescritti nella tabella; completare il rodaggio dei motori stessi sulle vetture.

Regime di prova (1/min)	Tempo in minuti	Carico al freno
800 ÷ 1000	10'	a vuoto
1500	10'	a vuoto
2000	10'	a vuoto

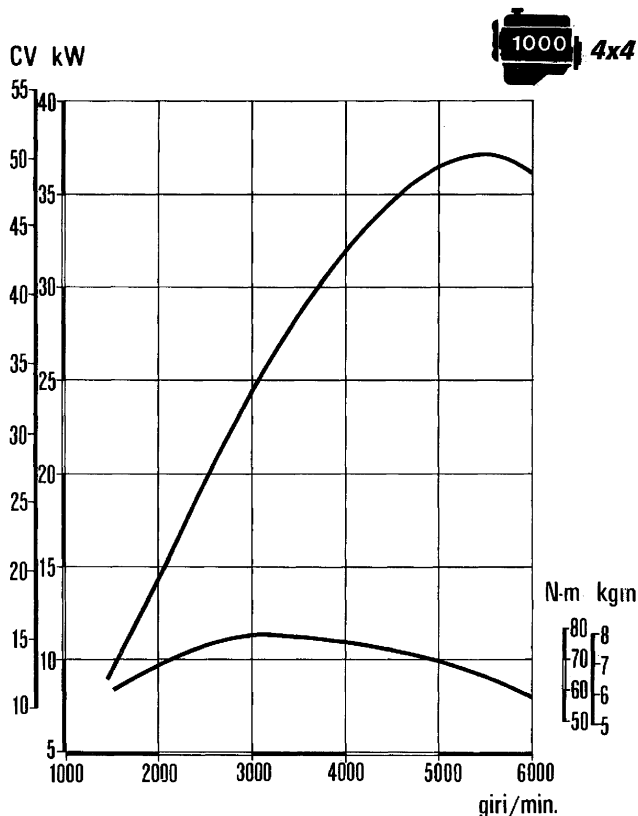

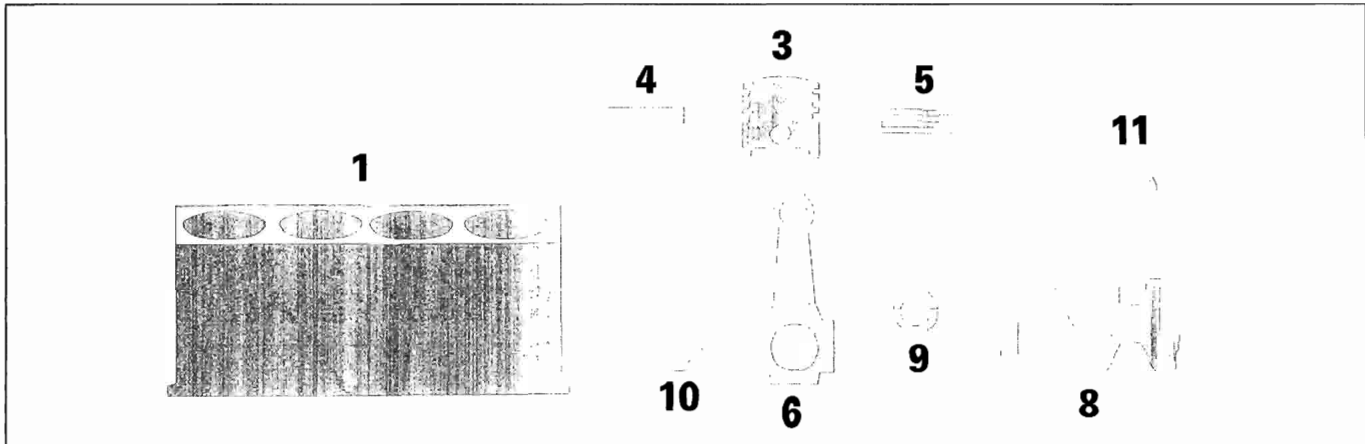









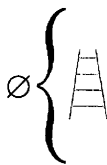

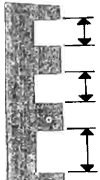
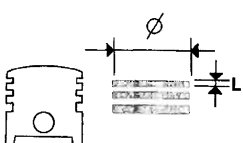
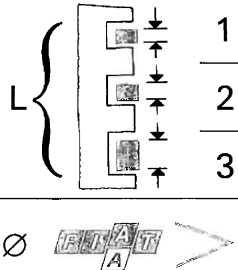

MISURE E ACCOPPIAMENTI

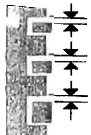
		Valori in mm		
1 Supporti di banco	L	19,14 ÷ 19,20		
	Ø	47,705 ÷ 47,718		
Canna cilindro $\varnothing \left(\begin{matrix} \text{A} \\ \text{C} \\ \text{E} \end{matrix} \right) 0,010$		65,000 ÷ 65,050	70,000 ÷ 70,050	
3 Stantuffo	X	16	13	
	$\varnothing \left\{ \begin{matrix} \text{A} \\ \text{C} \\ \text{E} \end{matrix} \right.$	A	64,960 ÷ 64,970	69,960 ÷ 69,970
		C	64,980 ÷ 64,990	69,980 ÷ 69,990
		E	65,000 ÷ 65,010	70,000 ÷ 70,010
	$\varnothing \begin{matrix} \text{E} \\ \text{C} \\ \text{A} \end{matrix} >$	0,4		
3 Differenza di peso fra stantuffi		± 5 g.		
3-1 Stantuffo - Canna cilindro		0,030 ÷ 0,050		
3 Sede perno stantuffo \varnothing		17,982 ÷ 17,986		

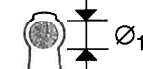
		
---	---	---

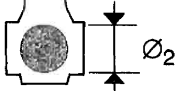

MISURE E ACCOPPIAMENTI

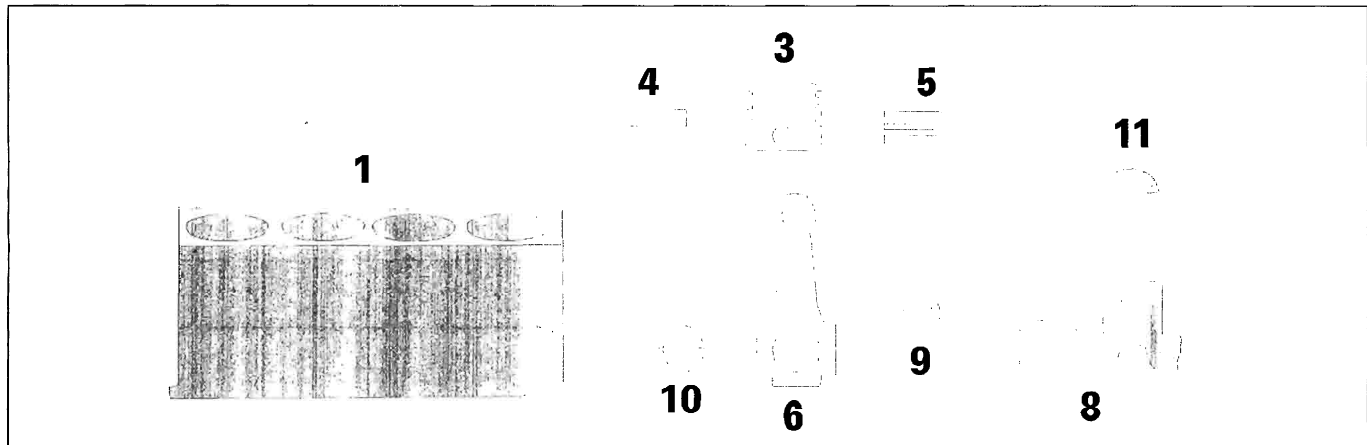
		Valori in mm	
4  Perno stantuffo		1	17,970 ÷ 17,974
		2	-
		3	-
		\varnothing 	-
4-3	 Perno stantuffo - Sede perno		0,008 ÷ 0,016
3  Cave anelli elastici		1	1,530 ÷ 1,550
		2	1,515 ÷ 1,535
		3	3,010 ÷ 3,030
5  Anelli elastici		1	1,480 ÷ 1,490
		2	1,478 ÷ 1,490
		3	2,975 ÷ 2,990
		\varnothing 	0,4
5-3  Anelli elastici Cave anelli elastici		1	0,040 ÷ 0,070
		2	0,025 ÷ 0,057
		3	0,020 ÷ 0,055
5-1  Apertura estremità anelli elastici nella canna cilindro		1	0,25 ÷ 0,45
		2	0,25 ÷ 0,45
		3	0,20 ÷ 0,45
6  Sede perno piede di biella		\varnothing_1	17,939 ÷ 17,956
		 Sede cuscinetti di biella	\varnothing_2
4-6	 Perno stantuffo Piede di biella		0,014 ÷ 0,035





MISURE E ACCOPPIAMENTI

		Valori in mm	
	Perni di banco $\left\{ \begin{array}{l} 1 \\ 2 \end{array} \right.$	1	43,990 ÷ 44,000
		2	43,980 ÷ 43,990
	Perni di biella \varnothing_2		37,988 ÷ 38,008
		L	23,975 ÷ 24,025
	Cuscinetti di banco $\left\{ \begin{array}{l} 1 \\ 2 \end{array} \right.$	1	1,834 ÷ 1,840
		2	1,839 ÷ 1,845
	\varnothing		0,254 – 0,508
9-8	Cuscinetti di banco-Perni		0,025 ÷ 0,060
	Cuscinetti di biella L		1,542 ÷ 1,548
	\varnothing		0,254 – 0,508
	10-8	Cuscinetti di biella-Perni	

 769	 1000	 1000 4x4
--	---	---

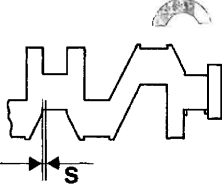
MISURE E ACCOPPIAMENTI

		Valori in mm
11 	Semianelli di spallamento S	2,310 ÷ 2,360
		0,127
11-8 	Spallamento albero motore	0,055 ÷ 0,265

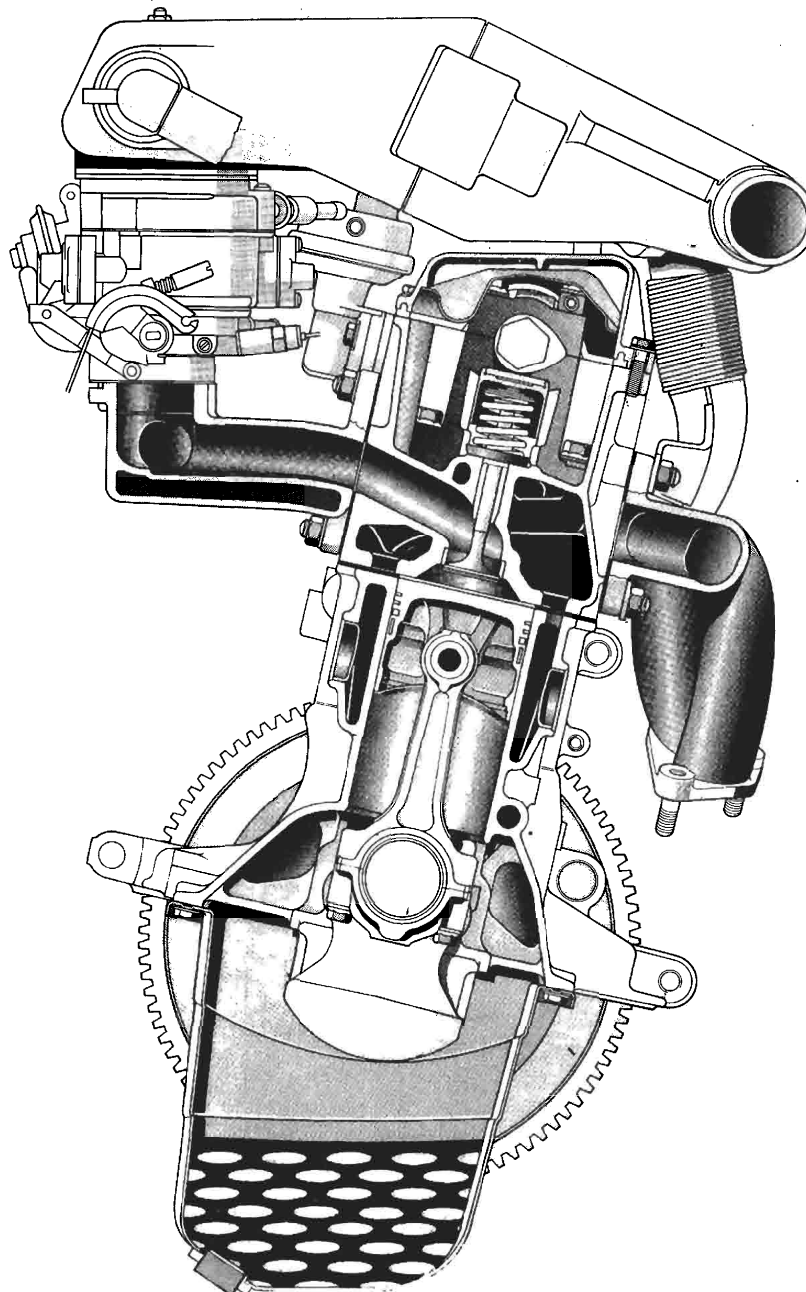

Sezione trasversale

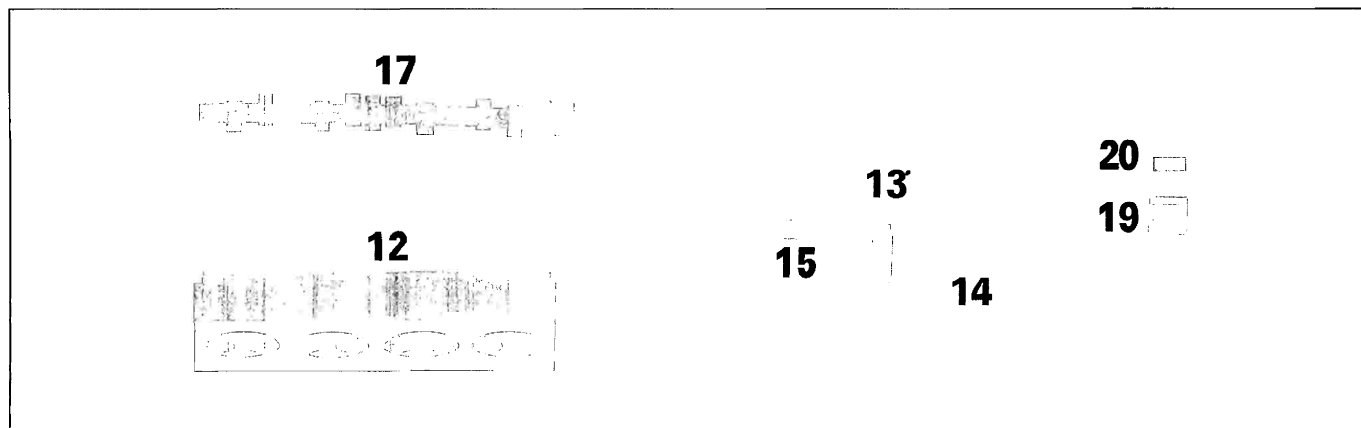

|--|--|--|

MISURE E ACCOPPIAMENTI

Valori in mm

	\varnothing_1	24,045 ÷ 24,070
	\varnothing_2	23,545 ÷ 23,570
<p>Sede perni albero distribuzione su testa cilindri</p>	\varnothing_3	24,045 ÷ 24,070
<p>Sede punterie su testa cilindri</p>	\varnothing	35,000 ÷ 35,025
<p>Sede guidavalvola su testa cilindri</p>	\varnothing	12,950 ÷ 12,977
<p>Sede valvole</p>	α	45° ± 5'
	L	~ 2
	\varnothing_1	7,022 ÷ 7,040
	\varnothing_2	13,010 ÷ 13,030
<p>Guidavalvola</p>	\varnothing_2	0,05-0,10-0,25

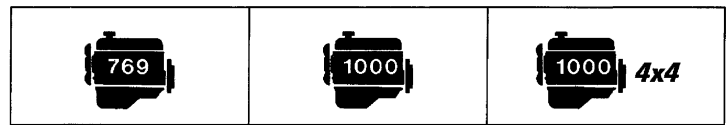

MISURE E ACCOPPIAMENTI

		Valori in mm			
13-12	<p>Guidavalvola - Sede su testa cilindri</p>	0,033 ÷ 0,080	0,063 ÷ 0,108		
14	<p>Valvole</p>		Ø ₁	6,970 ÷ 7,000	
			Ø ₂	26,20 ÷ 26,50	30,20 ÷ 30,50
			α	45° 30' ± 5'	
			Ø ₁	6,970 ÷ 7,000	
			Ø ₂	23,20 ÷ 23,50	27,20 ÷ 27,50
			α	45° 30' ± 5'	
14-13	<p>Valvola - Guidavalvola</p>	0,022 ÷ 0,070			
15	<p>Molla valvola</p>	P ₁	16,1 ÷ 18,7 daN		
		H ₁	31		
		P ₂	42,6 ÷ 46,8 daN		
		H ₂	24		
17	<p>Perni albero distribuzione</p>	Ø ₁	24,000 ÷ 24,015		
		Ø ₂	23,500 ÷ 23,515		
		Ø ₃	24,000 ÷ 24,015		
17	<p>Alzata camma</p>		7,1	7,1	8
17-12	<p>Perni albero distribuzione Sedi su testa cilindri</p>	Ø ₁	0,030 ÷ 0,070		
		Ø ₂	0,030 ÷ 0,070		
		Ø ₃	0,030 ÷ 0,070		

00.10

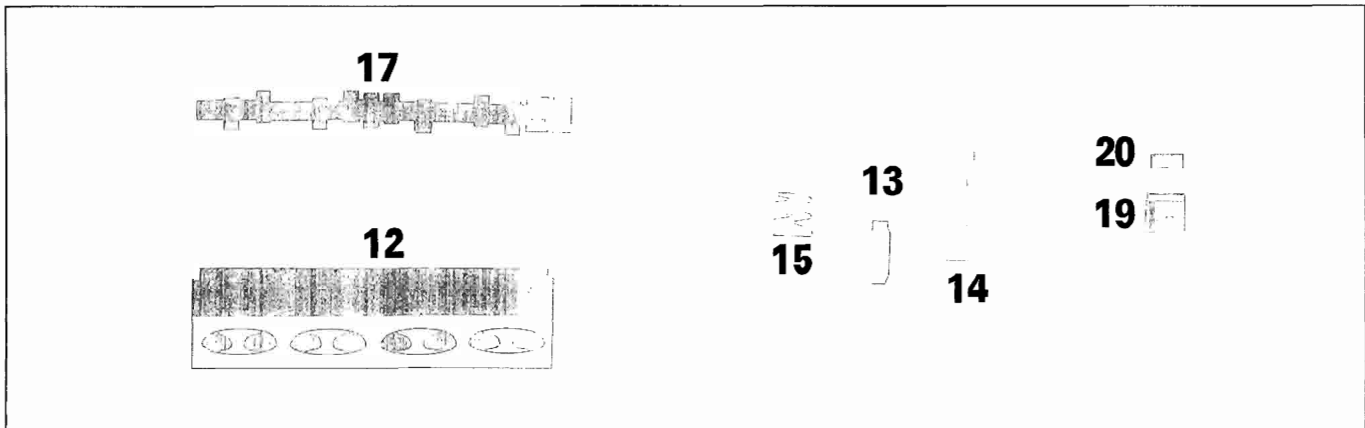

--	--	--





MISURE E ACCOPPIAMENTI

		Valori in mm		
19	 Punteria \varnothing	34,975 ÷ 34,995		
19-12	 Punteria Sede su testa cilindri	0,005 ÷ 0,050		
20	 Piattello S $\left(\begin{matrix} A \\ 0,05 \end{matrix} \right)$	3,20 ÷ 4,70		
17-20	 per controllo messa in fase	1	1	0,70
		0,30 ± 0,05		
		0,40 ± 0,05		
Volume della camera di combustione nella testa cilindri		cm ³	20,40	23,41

ANGOLI DI FASATURA

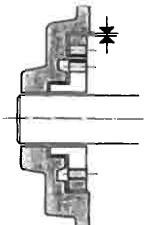
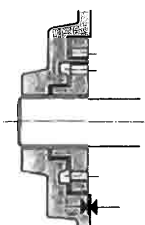
A	Aspirazione	inizio prima del PMS	1°	1°	2°
B		fine dopo il PMI	19°	19°	42°
C	Scarico	inizio prima del PMI	29°	29°	42°
D		fine dopo il PMS	-9°	-9°	2°

--	--	--

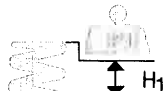

		Valori in mm
Circuito lubrificazione motore	a circolazione forzata mediante pompa a lobi con filtro olio a cartuccia in serie	
Pompa olio	ad ingranaggi a lobi	
Comando pompa	mediante albero motore	
Valvola regolazione pressione olio	incorporata nel coperchio anteriore albero motore	
 fra sede corpo pompa ed ingranaggio condotto	0,080 ÷ 0,186	
 tra il lato superiore degli ingranaggi e il coperchio pompa	0,025 ÷ 0,056	
Filtro a portata totale	a cartuccia	
Trasmettitore insufficiente pressione olio	elettrico	
   Pressione di funz. alla temperatura di 100°C	3,4 ÷ 4,9 bar	
 Molla valvola regolazione pressione olio	P ₁	4,45 ÷ 4,94 daN
	H ₁	34,1

Dati tecnici



Panda

Motore: raffreddamento - alimentazione

00.10

		
---	---	---

RAFFREDDAMENTO

Circuito di raffreddamento	a circolazione di liquido refrigerante mediante pompa centrifuga, radiatore ed elettroventilatore comandato da interruttore termometrico	
Comando pompa liquido refrigerante	mediante cinghia comando distribuzione	
 Interruttore termometrico per l'innesto del ventilatore		90° ÷ 94°C
		85° ÷ 89°C
Termostato liquido refrigerante motore	inizio apertura	85° ÷ 89°C
	apertura massima	100°C
	corsa valvola	≥ 7,5 mm
Pressione per controllo tenuta impianto	0,98 bar	
Controllo valvola di scarico su tappo serbatoio supplementare di espansione	0,98 bar	

ALIMENTAZIONE - Misure

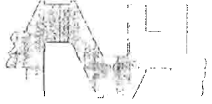
Pompa	meccanica a membrana	
Portata	60 litri/h	
 a 4000/min Minima pressione	 albero motore	> 0,2 bar

Controllo regime minimo motore ed emissioni ossido di carbonio



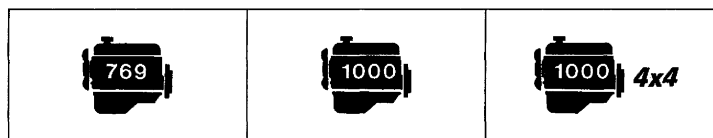



Regime di rotazione motore	1/min	750 ÷ 800
Emissione CO al minimo	(%)	1,5 ± 0,5



	WEBER 32 TLF 11/250	WEBER 32 TLF 6/250	WEBER 32 TLF 8/250
--	-------------------------------	------------------------------	------------------------------

CARBURATORI

Diffusore	mm	22		22
Centratore	mm	4		4,5
Getto principale	mm	1,05		1,05
Getto aria di freno	mm	1,70		1,65
Tubetto emulsionatore		F70		F70
Getto minimo	mm	0,47		0,46
Getto aria minimo	mm	0,50		0,50
Getto pompa	mm	0,40		0,40
Scarico pompa	mm	0,40		0,40
Getto di piena potenza	mm	0,50		0,50
Getto sovralimentatore	mm	–		0,40
Getto miscela sovralimentatore	mm	–		3,00
Valvola a spillo	mm	1,50		1,50
Foro ricircolo carburante	mm	–		–
Foro registro miscela minimo	mm	1,50		1,50
Boccola capsula sgolfamento	mm	0,40		0,40
Boccola miscela minimo	mm	1,30		1,30
Progressione	1° foro	mm	ASOLA 0,80 x 4,9	ASOLA 0,80 x 4,9
	2° foro	mm		
	3° foro	mm		
	4° foro	mm		
Livello meccanico con guarnizione	mm	26,5 ÷ 27,5		26,5 ÷ 27,5
Corsa galleggiante	mm	–		–
Portata pompa (10 pompate)	cm³	8 ÷ 12		8 ÷ 12
Apertura parziale farfalla 1° corpo	mm	–		–
Apertura totale farfalla 1° corpo/2° corpo	mm	–		–
Minimo veloce	mm	0,65 ÷ 0,75		0,65 ÷ 0,75
Sgolfamento pneumatico avviamento a freddo	apertura minima	mm	–	–
	apertura massima	mm	4 ÷ 5	4 ÷ 5
Sgolfamento meccanico	mm	–		–

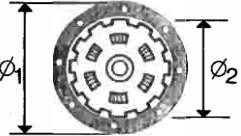
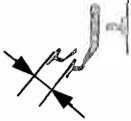





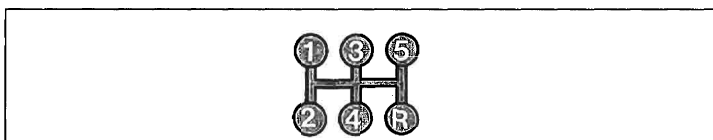



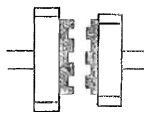

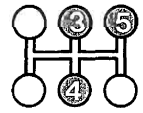

				
		Valori in mm		
Tipo		 monodisco a secco con cuscinetto a contatto		
 Meccanismo di innesto e disinnesto		 molla a disco		
Carico molla a disco		270 daN 225 daN*	375 daN 265 daN*	
 Disco condotto	\varnothing_1	170		
	\varnothing_2	120		
 Posizionamento pedale frizione		8 ÷ 12 mm al di sotto del piano pedale freno		
Comando frizione		meccanico		

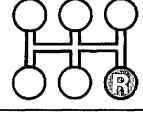
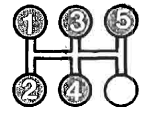
(*) In alternativa a seconda del fornitore.

 769 *	 1000	 1000 4x4
---	--	--





CAMBIO DI VELOCITÀ

 Sincronizzatori	{ ad anello elastico (tipo Porsche)  ad anello libero 				
 Ingranaggi	{ a denti dritti  a denti elicoidali 	 			
  Rapporto ingranaggi			3,909		
			2,056		
			1,344		
			0,978		
			0,837 (0,780▲)		
			3,727		





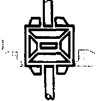

















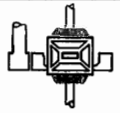



▲ Per versione **Panda 4x4**

(*) La **Panda** con motorizzazione 769 è equipaggiata di serie con cambio a 4 marce ed a richiesta con cambio a 5 marce nell'allestimento Super

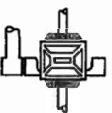
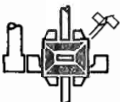

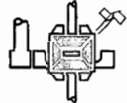







DIFFERENZIALE - RINVIO

 Rapporto	{ coppia conica di rinvio  coppia cilindrica di riduzione 	-		14/41 (0,341)
		13/55 (4,231)	15/58 (3,867)	11/60 (5,454)

00.21-27

				
DIFFERENZIALE - RINVIO				
	Rapporto coppia cilindrica di riduzione 	13/55 (4,231)	15/58 (3,867)	11/60 (5,454)
 		16,538	15,116	21,320
		8,698	7,950	11,213
		5,686	5,197	7,330
		4,137	3,782	5,334
		3,541	3,236	4,254
		15,768	14,412	20,327
		Cuscinetto scatola interna differenziale	 a rulli conici	
  	Registrazione precarico cuscinetti	 mediante anelli		
  	Spessore anelli di ricambio $\left(\begin{array}{c} \text{A} \\ \text{A} \end{array} \right) 0,10$ mm	0,40 ÷ 1,00		
	Interferenza prescritta per ottenere l'esatto precarico cuscinetti mm	cuscinetti scarichi = 0,12 cuscinetti carichi (350 daN) = 0,08		
	Precarico planetari-satelliti mm	≤ 0,10		
 	Registrazione interferenza planetari-satelliti	 mediante anelli		
  	Spessore anelli di ricambio $\left(\begin{array}{c} \text{A} \\ \text{A} \end{array} \right) 0,05$ mm	0,85 ÷ 1,15		



 <p>Rapporto coppia conica di rinvio</p>	<p>14/41 (0,341)</p>
 <p>Coppia di rotolamento cuscinetti pignone conico di rinvio</p>	<p>0,08 ÷ 0,12 daNm</p>
 <p>Registrazione posizione pignone conico di rinvio</p>	 <p>mediante anelli</p>
 <p>Spessore anelli di ricambio</p>	<p>mm</p> <p>2,55-2,59-2,65-2,69-2,75 2,79-2,85- 2,89-2,95-2,99 3,05-3,09-3,15-3,19-3,25 3,29-3,35</p>
 <p>Gioco fra pignone rinvio e corona</p>	<p>mm</p> <p>0,08 ÷ 0,15</p>
 <p>Registrazione giuoco fra pignone rinvio e corona</p>	 <p>mediante anelli</p>
 <p>Registrazione precarico cuscinetti</p>	<p>mediante anelli</p>
 <p>Spessore anelli di ricambio precarico e registrazione giuoco cuscinetti scatola interna differenziale</p>	<p>mm</p> <p>(0,10)</p> <p>0,40 ÷ 1,00</p>

00.24







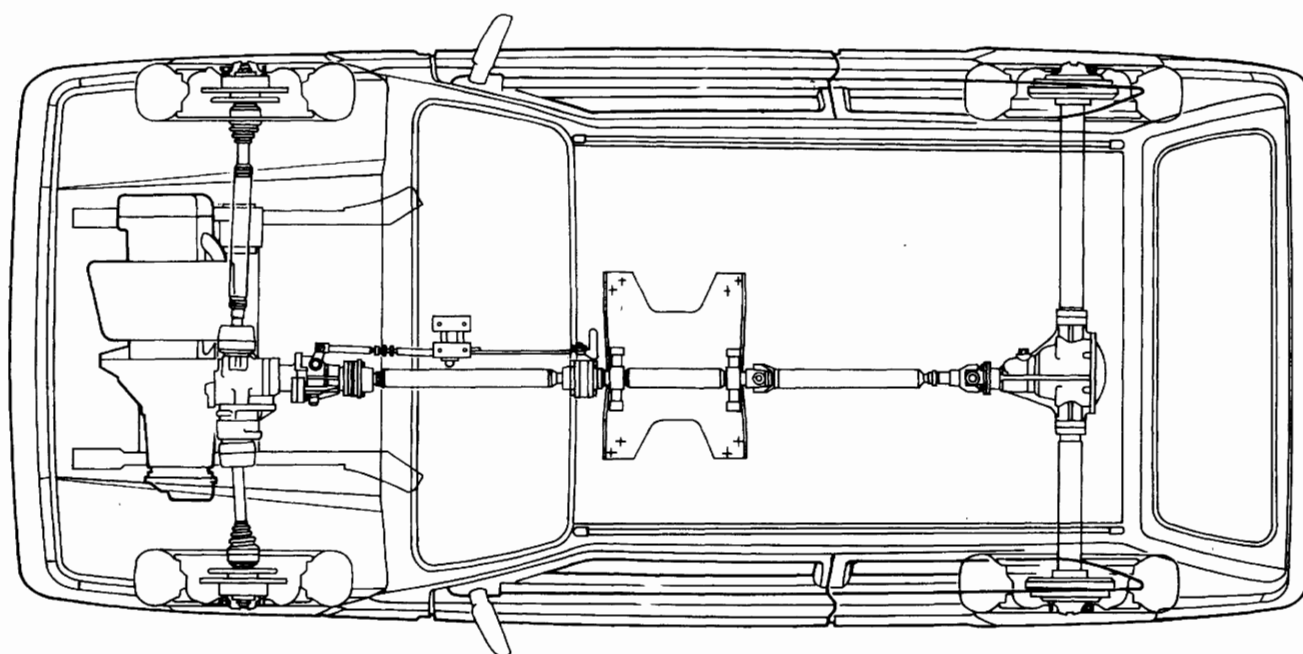



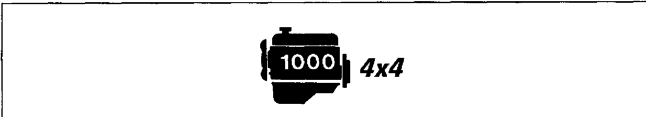

ALBERO DI TRASMISSIONE

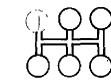
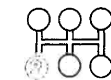
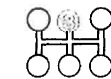
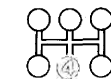
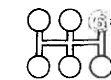
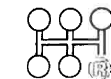
Tipo		in 3 tronchi
Supporti		2, con cuscinetti a sfere a tenuta stagna sul tronco centrale
Giunti omocinetici scorrevoli		2, sul tronco anteriore
Giunti cardanici		2, sul tronco posteriore
Giunto scanalato scorrevole		posteriore, sul tronco posteriore
Gioco radiale della crociera	mm	0,01 ÷ 0,04
Spessore anelli elastici di sicurezza per registrazione giuoco radiale della crociera	mm	1,50 - 1,53 - 1,56 - 1,59 - 1,62
Gioco tra le scanalature del giunto scanalato	mm	0,175 ÷ 0,350

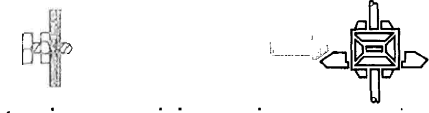



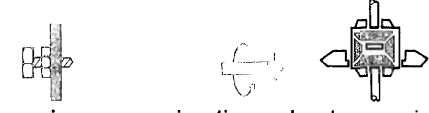



Schema della trasmissione del moto sulle quattro ruote (Panda 4x4)



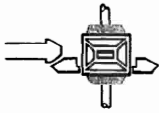

 <p>Rapporto coppia conica di riduzione</p>	<p>41 / 14 (2,928)</p>
 <p>Rapporto sulle ruote</p>	 <p>21,320</p>
	 <p>11,213</p>
	 <p>7,330</p>
	 <p>5,334</p>
	 <p>4,254</p>
	 <p>20,327</p>
 <p>Coppia di rotolamento cuscinetti pignone conico</p>	<p>0,08 ÷ 0,12 daNm</p>
 <p>Registrazione posizione pignone conico</p>	 <p>mediante anelli</p>
 <p>Spessore anelli di ricambio</p>	<p>2,55 - 2,59 - 2,65 - 2,69 - 2,75 2,79 - 2,85 - 2,89 - 2,95 - 2,99 3,05 - 3,09 - 3,15 - 3,19 - 3,25 - 3,29 - 3,35</p>
 <p>Coppia di rotolamento planetari satelliti</p>	<p>1, ÷ 6,8 daNm</p>
 <p>Registrazione coppia di rotol. planetari satelliti</p>	 <p>mediante anelli</p>
 <p>Spessore anelli di ricambio</p>	<p>2,75 ÷ 3,25</p>

00.27

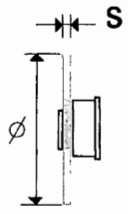
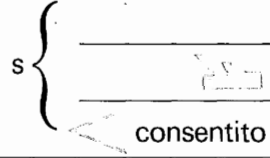

 Cuscinetto scatola interna differenziale	a rulli conici
 Precarico cuscinetti (divaricamento supporti per scatola interna differenziale)	mm 0,040 ÷ 0,050
 Giuoco fra pignone e corona	mm 0,08 ÷ 0,15
 Registrazione giuoco fra pignone e corona	
 Registrazione precarico cuscinetti	mediante anelli
 Spessore anelli di ricambio precarico cuscinetti scatola interna differenziale	mm 6,50 ÷ 7,50

FRENI ANTERIORI

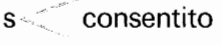
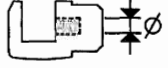
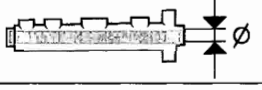
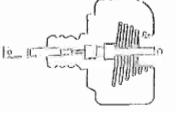
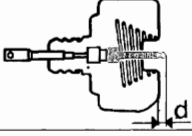
				Valori in mm
	Disco		Ø	227
				10,70 ÷ 10,90
				9,35
				9
	Guarnizioni di attrito			1,5
	Pinza		Ø	48
	Cilindro maestro (pompa)		Ø	19,05 (3/4")
	Servofreno			Master-Vac da 158,5 mm (6") idropneumatico a depressione agente sulle quattro ruote (*)
	Distanza del puntale comando stantuffo idraulico dalla piastra di appoggio cilindro maestro		d	0,825 ÷ 1,025 (*)



(*) Solo per versione **Panda 4x4**

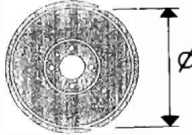
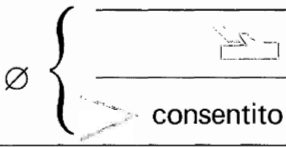
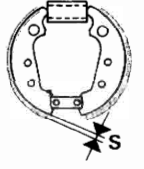
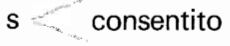
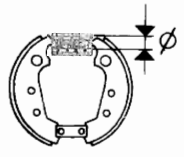



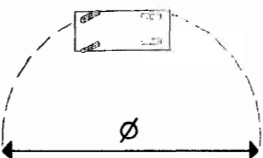
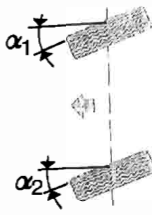
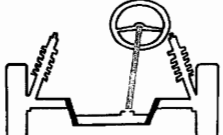

FRENI POSTERIORI

	Tamburo			185,24 ÷ 185,53
				186,33
				186,83
	Ganasce			1,5
	Cilindretti		Ø	19,05 (3/4")

00.41

		
---	---	---

<p>Tipo</p>	<p>a cremagliera</p>	
<p> Rapporto</p>	<p>3,8 giri</p>	
<p> corsa cremagliera</p>	<p>130 ± 1,5 mm</p>	
<p> Diametro minimo di sterzata \varnothing</p>	<p>9,45 m</p>	<p>9,22 m</p>
<p> Angolo di sterzata</p>	<p>ruota esterna α_1</p> <p>31 °</p>	<p>ruota interna α_2</p> <p>33 °30'</p>
<p> Piantone sterzo</p>	<p>con 2 giunti cardanici</p>	



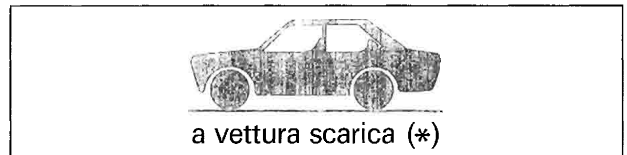
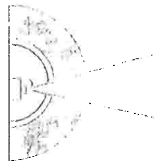

					
Ruote 	Pneumatico	tipo		135 SR 13" 155/65 SR 13" (★)	145 SR 13"
		anteriori	1,8 bar (▲)	2 bar (▲)	
		posteriori	2 bar (▲)	2 bar (▲)	
	Cerchio	tipo		4,00 B x 13"	

(★) A richiesta

(▲) Pressione di gonfiaggio a freddo

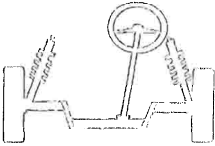
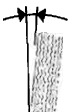

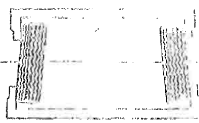
ASSETTO RUOTE

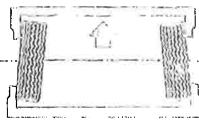
	inclinazione (**)		1° ± 30'	2°20' ± 30'
	incidenza (**)		2°30' ± 30'	3°30' ± 30'
	convergenza		-2 ± 2 mm	-4 ± 2 mm
	inclinazione (**)		-	
	convergenza (**)		-	

(*) Con pneumatici gonfiati alla pressione prescritta e vettura in ordine di marcia

(**) Angoli non registrabili

00.44

Sospensione anteriore a ruote indipendenti con bracci oscillanti inferiori e montanti telescopici costituiti ciascuno dal montante in lamiera collegato rigidamente all'ammortizzatore idraulico a doppio effetto.

Molla ad elica e tasselli di tamponamento coassiali con gli ammortizzatori.

Snodi che non richiedono ingrassaggio (for-life).

Molle ad elica

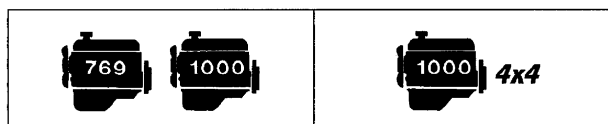

Altezza molla sotto un carico di:	$\left\{ \begin{array}{l} 208,5 \pm 8 \text{ daN} \\ 241 \pm 10 \text{ daN} \end{array} \right.$	mm	213	-
		mm	-	231
Le molle sono suddivise in due categorie, identificabili mediante contrassegno:				
giallo (1) quelle aventi sotto un carico di:	$\left\{ \begin{array}{l} 208,5 \pm 8 \text{ daN} \\ 241 \pm 10 \text{ daN} \end{array} \right.$	un'altezza di mm	>213	-
		un'altezza di mm	-	>231
verde (1) quelle aventi sotto un carico di:	$\left\{ \begin{array}{l} 208,5 \pm 8 \text{ daN} \\ 241 \pm 10 \text{ daN} \end{array} \right.$	un'altezza di mm	≤ 213	-
		un'altezza di mm	-	≤ 231

(1) Il montaggio deve effettuarsi con molle appaiate dello stesso contrassegno.

Ammortizzatori

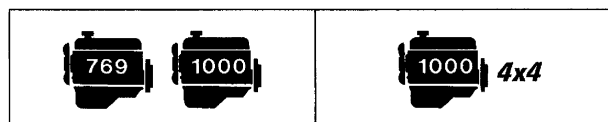

Tipo: telescopico, a doppio effetto		Way-Assauto	
Aperto (inizio tamponamento)	mm	428,5 ± 2	438,5 ± 2
Chiuso (ferro contro ferro)	mm	282,5 ± 2	292 ± 2
Corsa	mm	146	146,5



Sospensione posteriore a ponte rigido di struttura tubolare e di forma a Ω con incernieramento centrale e bracci di reazione longitudinali; molle elicoidali e ammortizzatori telescopici a doppio effetto.



Sospensione posteriore ad assale rigido tubolare collegato alla scocca con due balestre longitudinali a tre foglie e tasselli elastici. Ammortizzatori idraulici telescopici a doppio effetto.

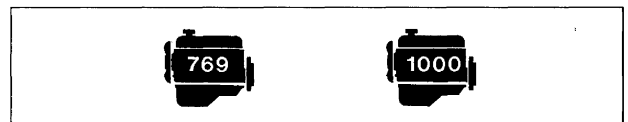

Molle ad elica

Altezza molla sotto un carico di 257 daN	mm	170
Le molle sono suddivise in due categorie, identificabili mediante contrassegno: giallo (1) quelle aventi sotto un carico di 257 daN	un'altezza di mm	> 170
verde (1) quelle aventi sotto un carico di 257 daN	un'altezza di mm	≤ 170

(1) Il montaggio deve effettuarsi con molle appaiate dello stesso contrassegno.

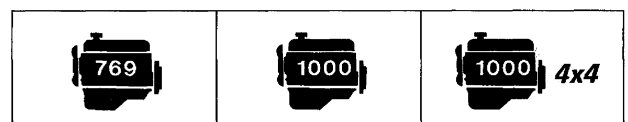

Ammortizzatori



Tipo: telescopico, a doppio effetto		Way-Assauto	
Aperto (inizio tamponamento)	mm	420 \pm 3	340 \pm 3
Chiuso (ferro contro ferro)	mm	253 \pm 3	195 \pm 3
Corsa	mm	168	145

00.44

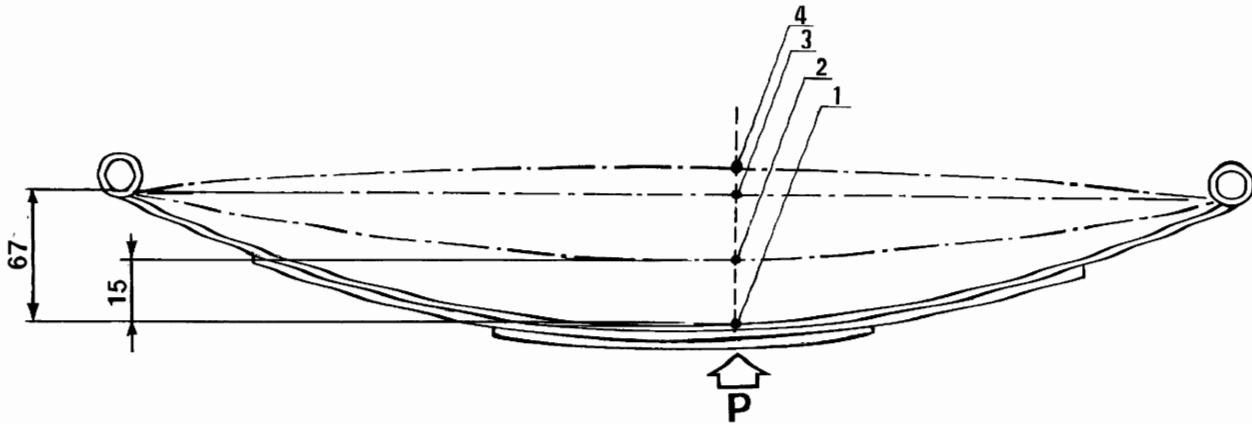
MOLLE A BALESTRA



Posizione		Carico daN	Freccia mm	Cedimento elastico a partire dalla posizione 1	Flessibilità mm/100 daN
1	Inizio controllo flessibilità	100	-	-	45,4
2	Carico di riferimento	134	42,5 ± 3	15 ± 1	
3	Fine controllo flessibilità	250	-	67 ± 5	
4	Carico di tamponamento massimo	355	-	115 ± 9	-

 769	 1000	 1000 4x4
--	--	---

MOTORE DI AVVIAMENTO	M. Marelli E 95-0,8 kW-12 V	
ALTERNATORE	M. Marelli AA 125R-14 V-45 A	
REGOLATORE DI TENSIONE (elettronico incorporato)	M. Marelli RTT 119 A	
BATTERIA	30 Ah - 12 V - 140 A	
DISTRIBUTORE DI ACCENSIONE	M. Marelli S 181 A	M. Marelli SE 101 C
ROCCHETTO DI ACCENSIONE	M. Marelli BE 200 B Bosch 0.221.119.048 Klitz OEM G 52 S Iskra ATA 0115	M. Marelli BAE 506 A
CANDELE	M. Marelli 7 LCR Champion RC 9 YC	Bosch FR 6 DC Bosch FR 7 DC Bosch FR 8 DC

00.55

Motore: tipo		M. Marelli E 95-0,8 kW-12 V					
Tensione	V	12					
Potenza nominale	kW	0,8					
Rotazione, lato pignone		destrorsa					
Poli		4					
Eccitazione		avvolgimenti in serie					
Innesto		a ruota libera					
Comando		elettromagnetico					
Gioco assiale dell'albero indotto		mm 0,1 ÷ 0,4					
Dati per la prova al banco	Prova di funzionamento (*):						
	corrente	A 180					
	velocità	1/min 1720					
	tensione	V 9,1					
	coppia sviluppata	daNm 0,37					
	Prova di spunto (*):						
	corrente	A 324					
	tensione	V 7,1					
	coppia sviluppata	daNm ≥ 0,97					
Prova a vuoto (*):							
corrente	A 40						
tensione	V 11,4						
velocità	1/min 8500 ÷ 9000						
Teleruttore	Resistenza dell'avvolgimento (*)	<table style="display: inline-table; vertical-align: middle;"> <tr> <td rowspan="2" style="font-size: 2em; vertical-align: middle;">}</td> <td>strappo Ω</td> <td>0,30 ÷ 0,32</td> </tr> <tr> <td>ritegno Ω</td> <td>1,2 ÷ 1,3</td> </tr> </table>	}	strappo Ω	0,30 ÷ 0,32	ritegno Ω	1,2 ÷ 1,3
}	strappo Ω	0,30 ÷ 0,32					
	ritegno Ω	1,2 ÷ 1,3					
Lubrificazione	Scanalature interne dell'innesto e boccole albero	VS+ SAE 10 W					
	Manicotto d'innesto e relativo disco intermedio	TUTELA MR3					

(*) Dati rilevati alla temperatura ambiente di 20°C.

NOTA In sede di revisione non è richiesta la ribassatura dell'isolante tra le lamelle del collettore

MOTORE AVVIAMENTO - CURVE CARATTERISTICHE

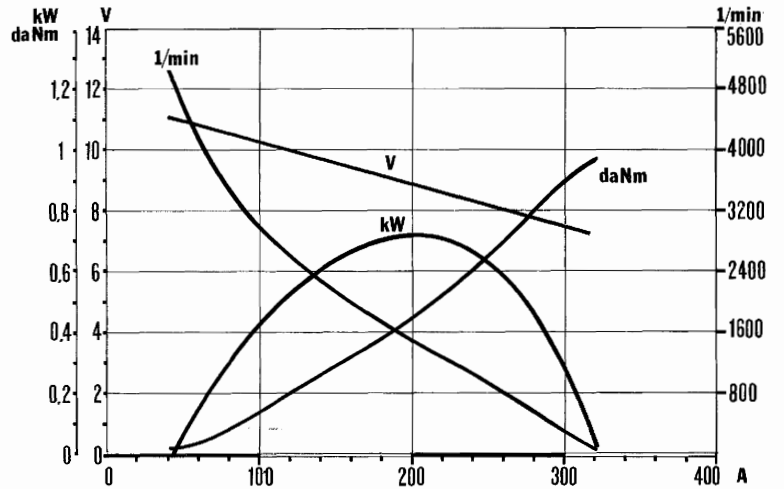

M. Marelli E 95 - 0,8 kW - 12 V

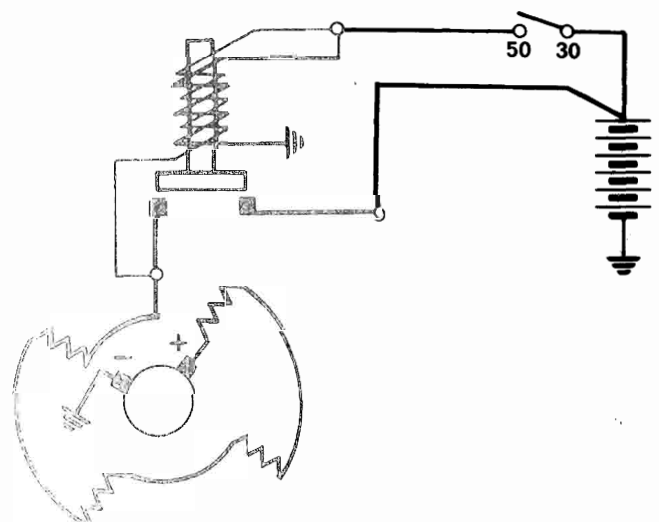

Schema elettrico del motore d'avviamento

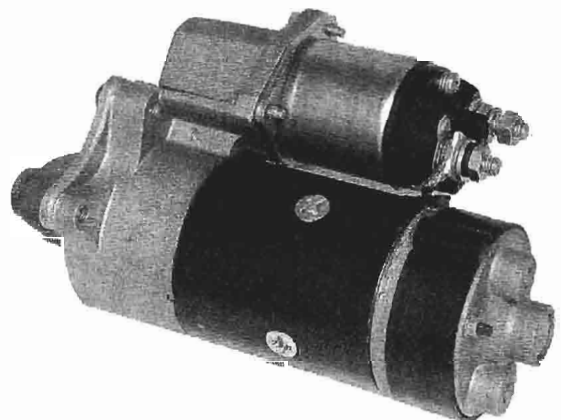

Motore d'avviamento
M. Marelli E 95 - 0,8 kW - 12 V

00.55

ALTERNATORE

Tipo		M. Marelli AA125R-14V-45A
Tensione nominale dell'impianto	V	14
Corrente massima	A	~ 47
Velocità di inizio carica a caldo	1/min	1050
Corrente erogata su batteria a 7000/min ed a regime termico	A	≥ 45
Resistenza avvolgimento induttore, tra i due anelli collettori (*)	Ω	3 ÷ 3,2
Senso di rotazione (visto dal lato comando)		destrorso
Diodi raddrizzatori di potenza		a ponte preconstituito

(*) Dati rilevati alla temperatura ambiente di 20°C

REGOLATORE DI TENSIONE

Elettronico incorporato nell'alternatore	tipo	M. Marelli RTT 119 A
Velocità alternatore per controllo	1/min	6000
Corrente per stabilizzazione termica	A	20 ÷ 25
Corrente di controllo	A	5 ÷ 45
Tensione di regolazione (*)	V	14 ÷ 14,3

(*) Dati rilevati alla temperatura ambiente di 20°C

BATTERIA

Tensione nominale	V	12
Capacità (alla scarica di 20 ore)	Ah	30

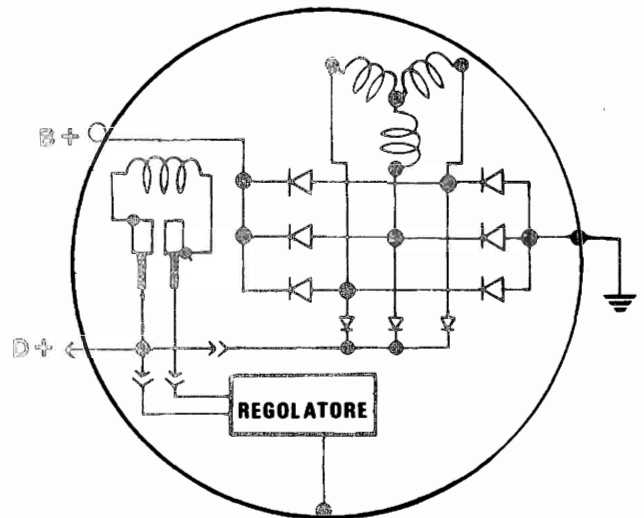

Schema elettrico dell'alternatore

Curva caratteristica di erogazione dell'alternatore a regime termico con tensione costante di 13,5 V e spazzole assestate

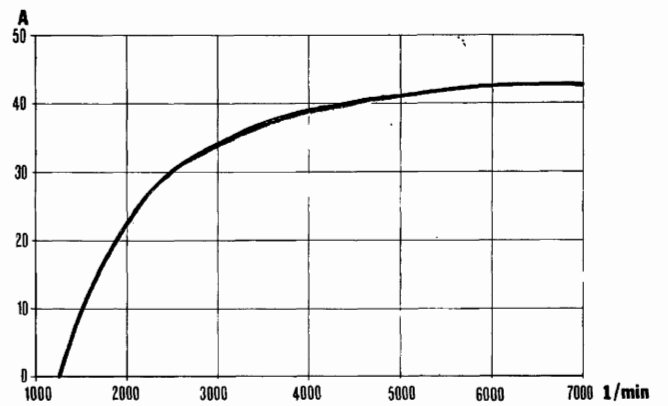

00.55



DISTRIBUTORE D'ACCENSIONE

Tipo	M.Marelli
Sigla	S 181 A
Anticipo iniziale di calettamento su motore	2°
Anticipo automatico centrifugo su motore	28° ± 2°
Correttore di anticipo a depressione	13° ± 1°
Apertura contatti del ruttore mm	0,45
Angolo di apertura della camma	37° ± 2°
Angolo di chiusura della camma	53° ± 2°
Capacità del condensatore a 50 ÷ 1000 Hz µF	0,20 ÷ 0,25
Ordine di accensione	1 - 3 - 4 - 2

ROCCHETTO D'ACCENSIONE

Tipo	M.Marelli	Bosch	Klitz OEM	Iskra
Sigla	BE 200 B	0.221.119.048	G 52 S	ATA 0115
Resistenza ohmmica del primario (*) Ω	3 ÷ 3,3	2,6 ÷ 3,1	2,68 ÷ 2,96	3,17 ÷ 3,43
Resistenza ohmmica del secondario (*) Ω	8500 ÷ 10500	8500 ÷ 12000	6745 ÷ 7455	6750 ÷ 8250

(*) Dati rilevati alla temperatura ambiente di 20°C

CANDELE DI ACCENSIONE

Sigla	M. Marelli 7 LCR Champion RC 9 YC	Bosch FR 6 DC Bosch FR 7 DC Bosch FR 8 DC
Filettatura di attacco sul motore	M 14 x 1,25	
Distanza fra gli elettrodi mm	0,7 ÷ 0,8	



Diagramma dell'anticipo automatico del distributore d'accensione su motore



Diagramma dell'anticipo a depressione del distributore d'accensione su motore

00.55**ACCENSIONE ELETTRONICA**

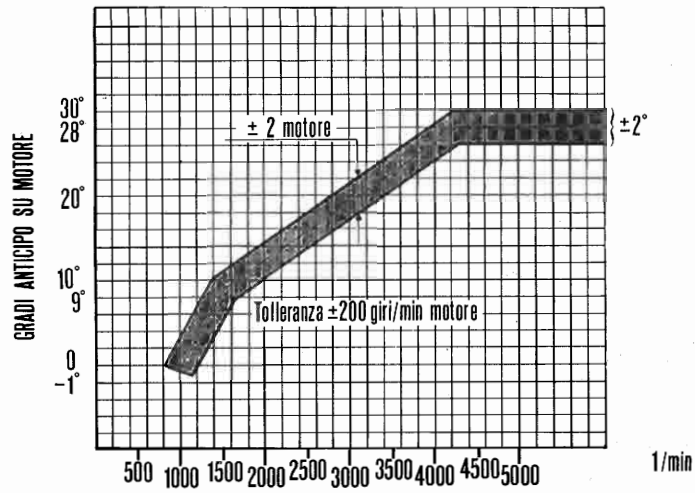
Accensione elettronica breakerless	M. Marelli
Ordine d'accensione	1-3-4-2

DISTRIBUTORE

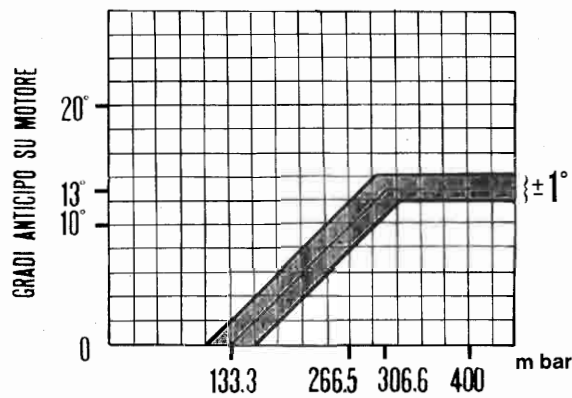
Tipo	M. Marelli
Sigla	SE 101 C
Anticipo iniziale di calettamento, su motore	2°
Anticipo automatico centrifugo massimo su motore	28° ± 2°
Anticipo a depressione massimo	13° ± 1°
Distanza fra il rotore a 4 poli ed il polo statorico	mm 0,30 ÷ 0,40
Resistenza avvolgimento bobina dell'impulsore elettromagnetico (*)	Ω 758 ÷ 872

ROCCHETTO

Tipo	M. Marelli
Sigla	BAE 506 A
Resistenza ohmmica del primario (*)	Ω 0,756 ÷ 0,924
Resistenza ohmmica del secondario (*)	Ω 3330 ÷ 4070

CANDELE

Tipo e sigla	M. Marelli 7 LCR Champion RC 9 YC Bosch FR 6 DC Bosch FR 7 DC Bosch FR 8 DC
Filettatura di attacco sul motore	M 14 x 1,25
Distanza fra gli elettrodi	mm 0,7 ÷ 0,8

(*) Dati rilevati alla temperatura ambiente di 20°C

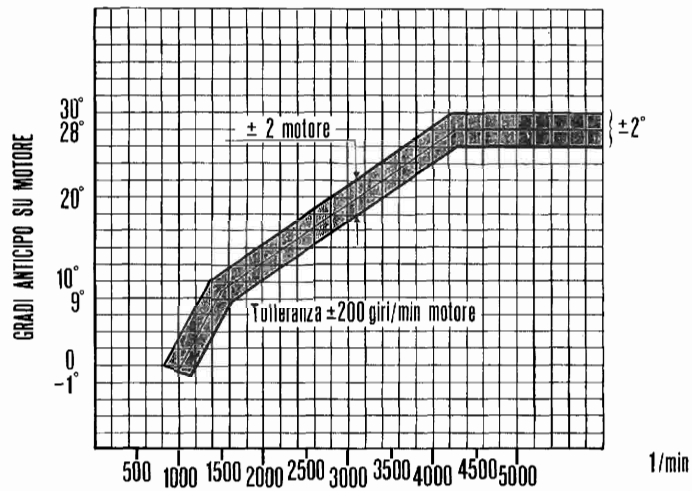

Diagramma dell'antico automatico del distributore d'accensione su motore

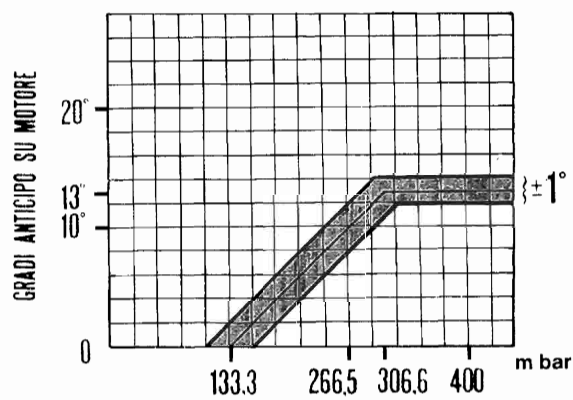

Diagramma dell'antico a depressione del distributore d'accensione su motore